

PRODUCT:

3030 SURFACE MOUNT LED

FEATURES:

3.0 mm × 3.0 mm × 0.6 mm surface-mount LED
 120° emission angle
 95 min CRI

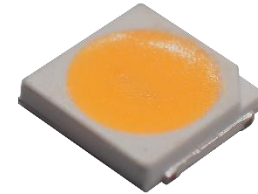

DESCRIPTION

YUJILEDS® VTC 3030 SMD provides true full spectrum coverage and ultra-high CRI using violet die technology. Providing 98 CRI (typical), this mid-power LED can be used in a variety of applications demanding high color quality and performance.



ELECTRICAL-OPTICAL CHARACTERISTICS (T _c = 25 °C)							
PARAMETER	SYMBOL	VALUE			UNIT	TOLERANCE	CONDITION
		MIN.	TYP.	MAX.			
Forward voltage	V _f	3.0	--	3.4	V	±0.05	I _f = 60mA
Luminous flux	Φ _{2700K}	11	--	14	lm	--	I _f = 60mA
	Φ _{3200K}	12		15			
	Φ _{4000K}	12		15			
	Φ _{5000K}	13		16			
	Φ _{5600K}	13		16			
	Φ _{6500K}	13		16			
Correlated color temperature	CCT _{2700K}	2550	2700	2850	K	--	I _f = 60mA
	CCT _{3200K}	3050	3200	3350			
	CCT _{4000K}	3800	4000	4200			
	CCT _{5000K}	4700	5000	5300			
	CCT _{5600K}	5300	5600	5900			
	CCT _{6500K}	6000	6500	7000			
Color rendering index	R _a	95	--	--	--	±1	I _f = 60mA
TCS R9 (CRI Red)	R ₉	--	90	--	--	--	I _f = 60mA
Chromaticity coordinates	(X,Y)	--	--	--	--	±0.005	--
Reverse current	I _r	--	--	10	μA	±0.1	V _r = 5V
Viewing angle	2θ _{1/2}	--	120	--	Deg	±5	I _f = 60mA

* This data is for reference only

ORDERING INFORMATION			
PART NUMBER	CCT	CHROMATICITY BINS	VOLTAGE RANGE
YJ-VTC-3030L-G02-27	2700K ± 150K	V27L, V27R	0.1 V
YJ-VTC-3030L-G02-32	3200K ± 150K	V32L, V32R	0.1 V
YJ-VTC-3030L-G02-40	4000K ± 200K	V40L, V40R	0.1 V
YJ-VTC-3030L-G02-50	5000K ± 300K	V50L, V50R	0.1 V
YJ-VTC-3030L-G02-56	5600K ± 300K	V56L, V56R	0.1 V
YJ-VTC-3030L-G02-65	6500K ± 500K	V65L, V65R	0.1 V
YJ-VTC-3030L-GXX-XX	CUSTOM		

VOLTAGE BIN CODES				
Bin	V30	V31	V32	V33
V _F	3.0-3.1	3.1-3.2	3.2-3.3	3.3-3.4

ABSOLUTE MAXIMUM RATING (T _c = 25 °C)			
PARAMETER	SYMBOL	LIMIT	UNIT
Power Consumption	P _D	330	mW
DC Forward Current (pulsed)*	I _{Fp}	180**	mA
DC Forward Current	I _F	90	mA
Reverse Voltage	V _R	5	V
Junction Temperature	T _j	120	°C
Solder Point Temperature***	T _s	85	°C
Operating Temperature	T _{opr}	-40 ~ +85	°C
Storage Temperature	T _{stg}	-30 ~ +100	°C
Soldering Temperature	T _{sol}	260 ± 5	°C
Reflow Cycles Allowed	--	2	--

* Pulse width ≤ 0.1ms, Duty ≤ 1/10.

** Theoretical data.

*** See page 4 for solder point definition.

CHROMATICITY BINS & COORDINATES									
CCT	BIN	CIE 1931 COORDINATES							
		X0	Y0	X1	Y1	X2	Y2	X3	Y3
6500K	V65L	0.3045	0.3261	0.3069	0.3141	0.3139	0.3212	0.3123	0.3335
	V65R	0.3123	0.3335	0.3139	0.3212	0.3222	0.3293	0.3214	0.3413
5600K	V56L	0.3232	0.3470	0.3239	0.3338	0.3301	0.3389	0.3298	0.3529
	V56R	0.3298	0.3529	0.3301	0.3389	0.3371	0.3447	0.3376	0.3595
5000K	V50L	0.3376	0.3605	0.3371	0.3453	0.3450	0.3518	0.3462	0.3672
	V50R	0.3462	0.3672	0.3450	0.3518	0.3540	0.3590	0.3560	0.3743
4000K	V40L	0.3737	0.3793	0.3703	0.3633	0.3784	0.3687	0.3824	0.3847
	V40R	0.3824	0.3847	0.3784	0.3687	0.3873	0.3742	0.3921	0.3902
3200K	V32L	0.4187	0.4065	0.4125	0.3906	0.4213	0.3940	0.4284	0.4103
	V32R	0.4284	0.4103	0.4213	0.3940	0.4309	0.3972	0.4389	0.4143
2700K	V27L	0.4525	0.4160	0.4440	0.4000	0.4552	0.4025	0.4642	0.4185
	V27R	0.4642	0.4185	0.4552	0.4025	0.4672	0.4048	0.4775	0.4215

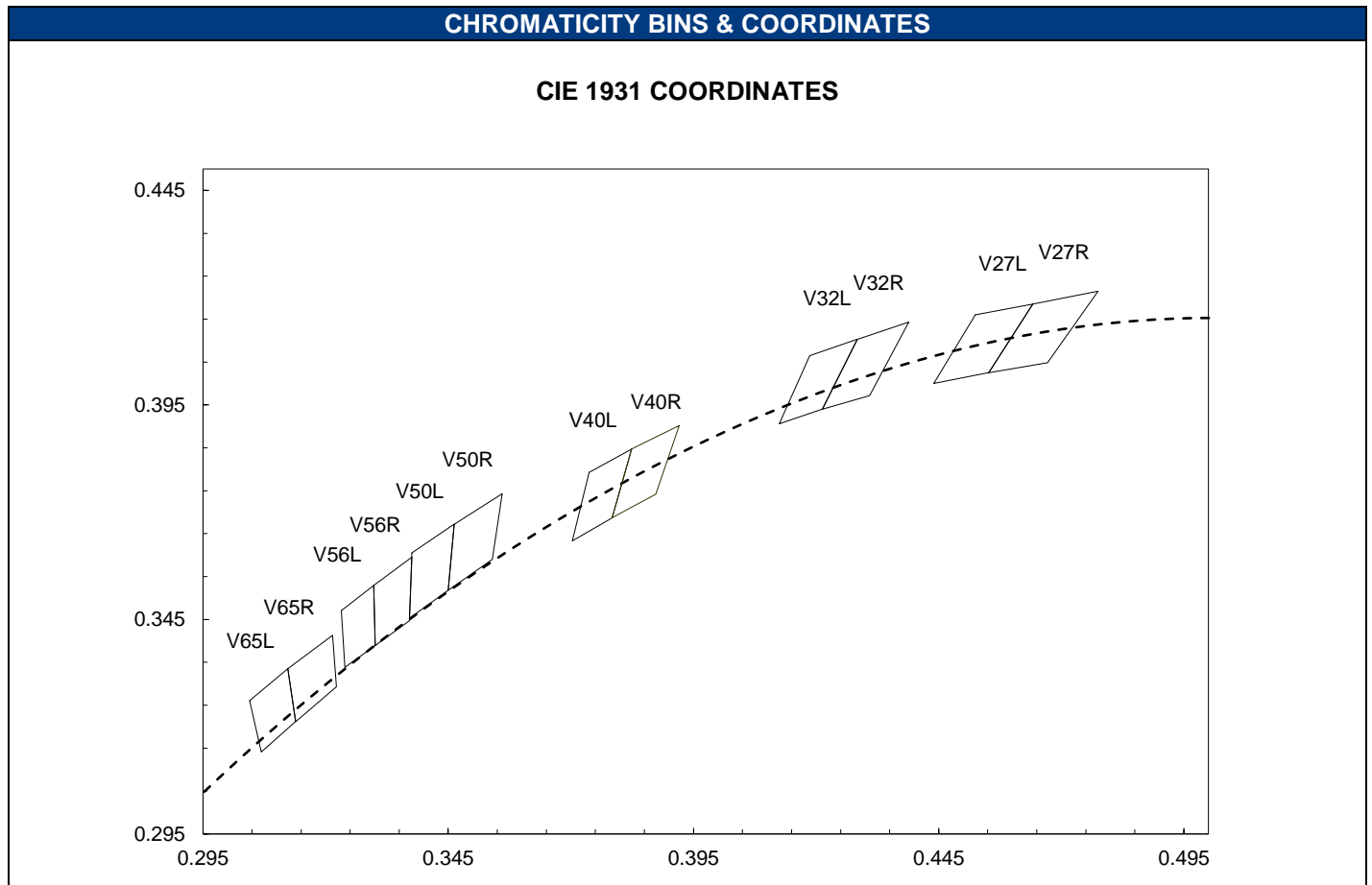

PACKAGE LAYOUT

Tolerance is $\pm 0.1\text{mm}$ unless otherwise noted.

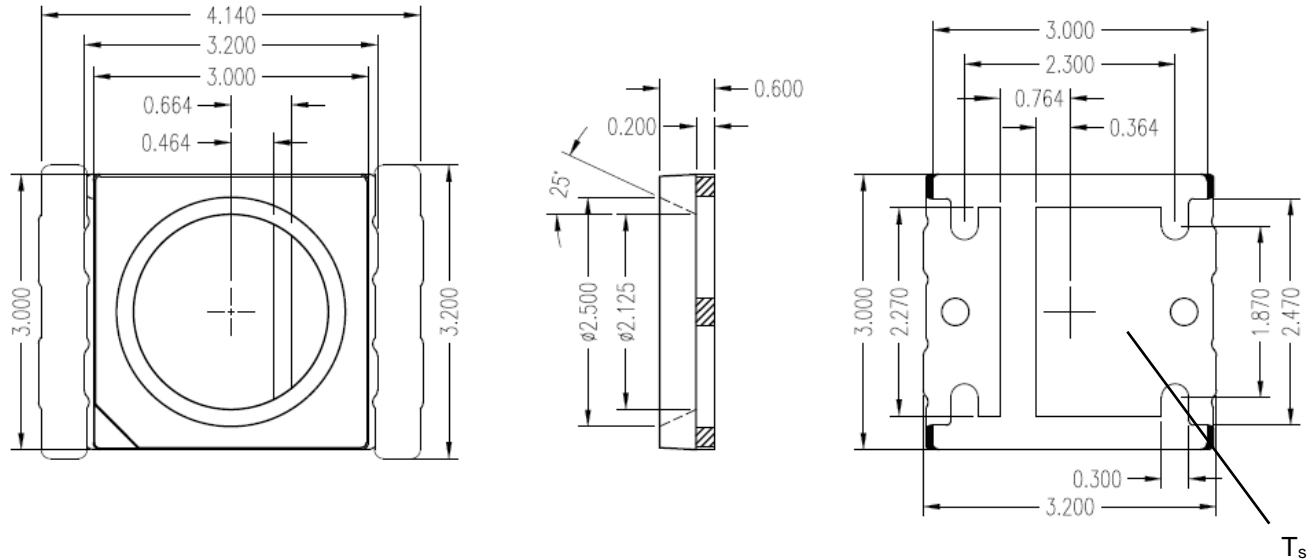

PACKAGE MATERIALS

ITEM	DESCRIPTION
DIE MATERIAL	InGaN
LEAD FRAME MATERIAL	EMC
ENCAPSULANT RESIN MATERIAL	SILICONE + PHOSPHOR
ELECTRODES MATERIAL	SILVER-PLATED COPPER

RECOMMENDED SOLDER PAD LAYOUT

Tolerance is $\pm 0.1\text{mm}$ unless otherwise noted.

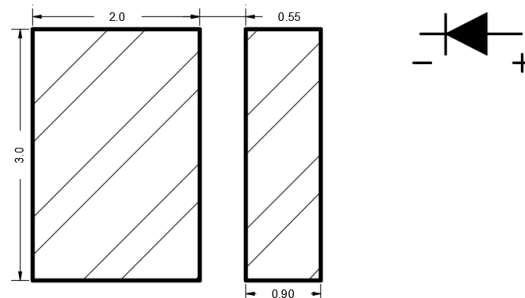

CHARACTERISTIC CURVES

ALL CHARACTERISTIC CURVES ARE FOR REFERENCE ONLY AND NOT GUARANTEED

FORWARD CURRENT VS FORWARD VOLTAGE ($T_A = 25^\circ\text{C}$)

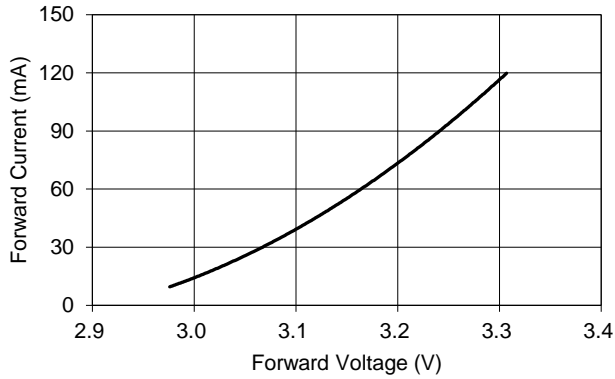

FORWARD CURRENT VS RELATIVE LUMINOUS OUTPUT ($T_A = 25^\circ\text{C}$)

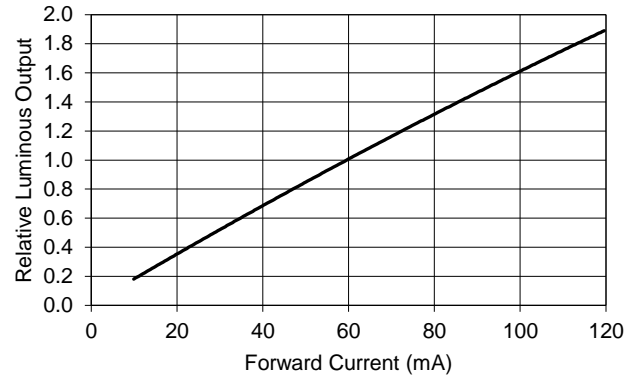

SOLDER POINT TEMPERATURE VS FORWARD VOLTAGE ($I_F = 60\text{ mA}$)

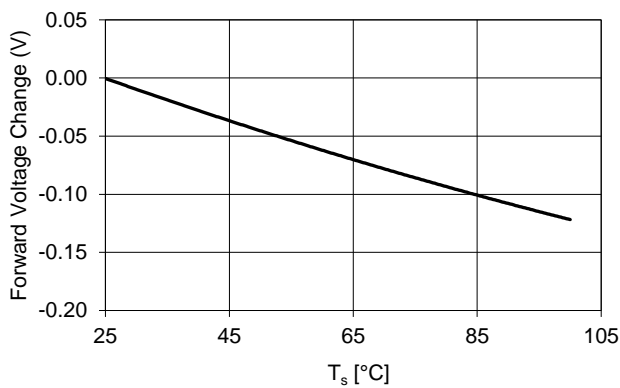

SOLDER POINT TEMPERATURE VS RELATIVE LUMINOUS OUTPUT ($I_F = 60\text{ mA}$)

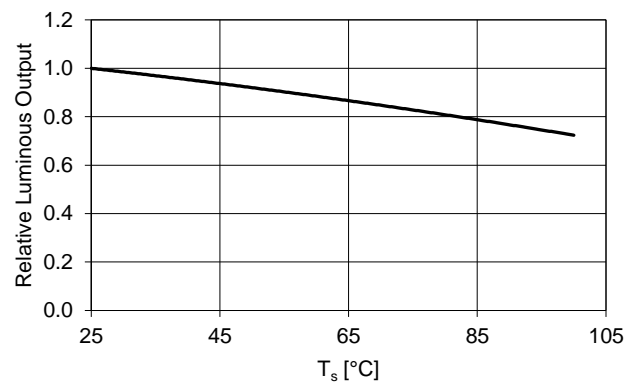

FORWARD CURRENT VS CHROMATICITY SHIFT (5600K, $T_A = 25^\circ\text{C}$)

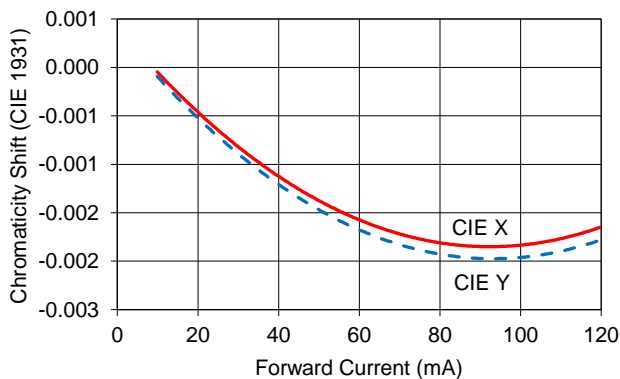

FORWARD CURRENT VS CHROMATICITY SHIFT (5600K, $T_A = 25^\circ\text{C}$)

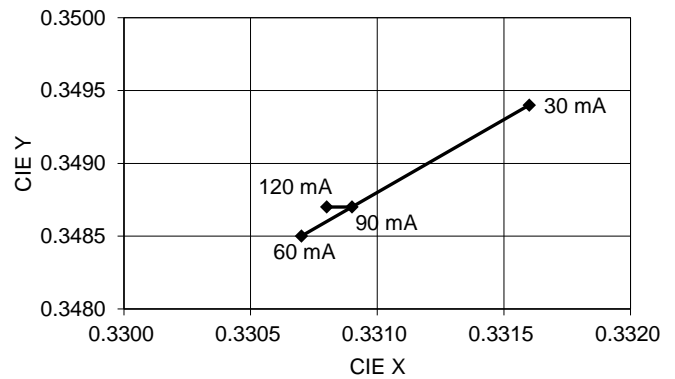

CHARACTERISTIC CURVES (CONTINUED)

SOLDER POINT TEMPERATURE VS CHROMATICITY (5600K, $I_F = 60$ mA)

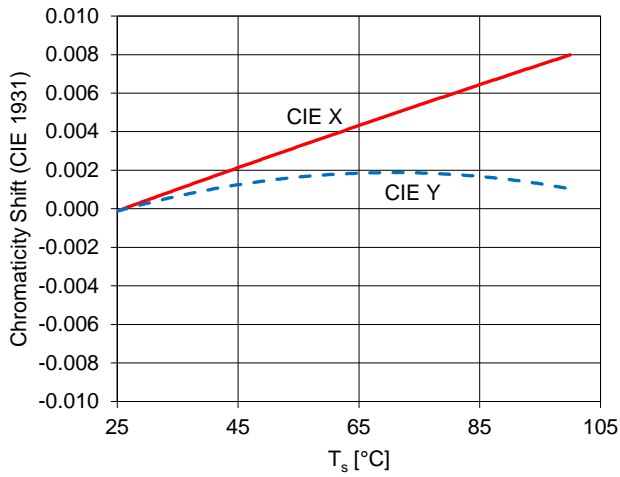

SOLDER POINT TEMPERATURE VS CHROMATICITY (5600K, $I_F = 60$ mA)

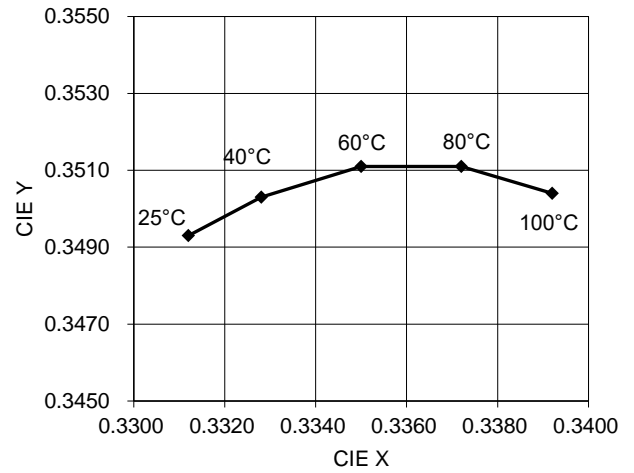

FORWARD CURRENT DERATING BASED ON SOLDER POINT

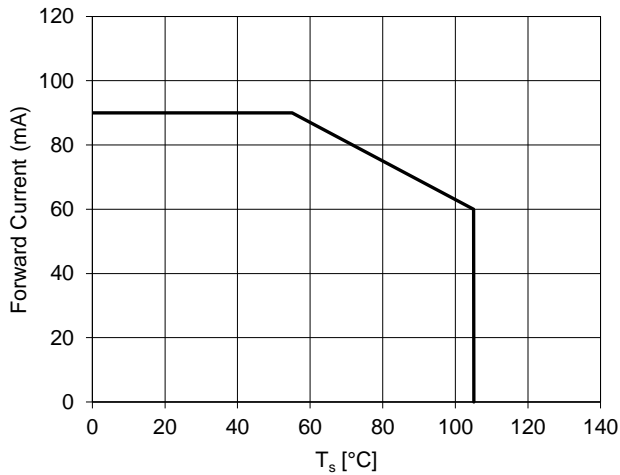

NOTE: DE-RATING CURVES ARE MEANT FOR RECOMMENDATION ONLY AND ARE NOT MEANT TO PROVIDE GUARANTEES OF PRODUCT STABILITY AND LONGEVITY

TYPICAL SPATIAL DISTRIBUTION ($T_A = 25^\circ\text{C}$, $I_F = 60$ mA)

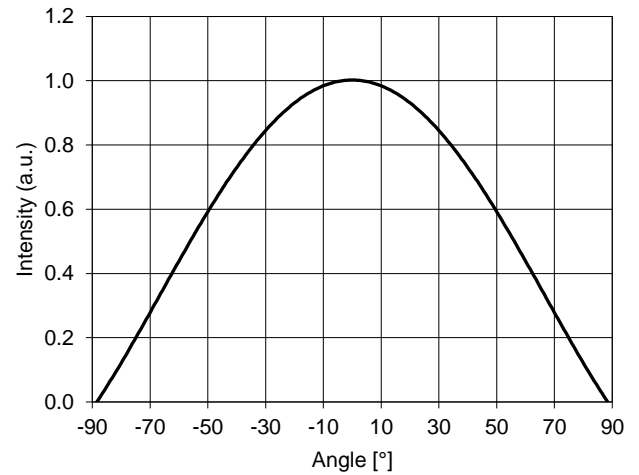

TYPICAL SPECTRAL DISTRIBUTION GRAPHS

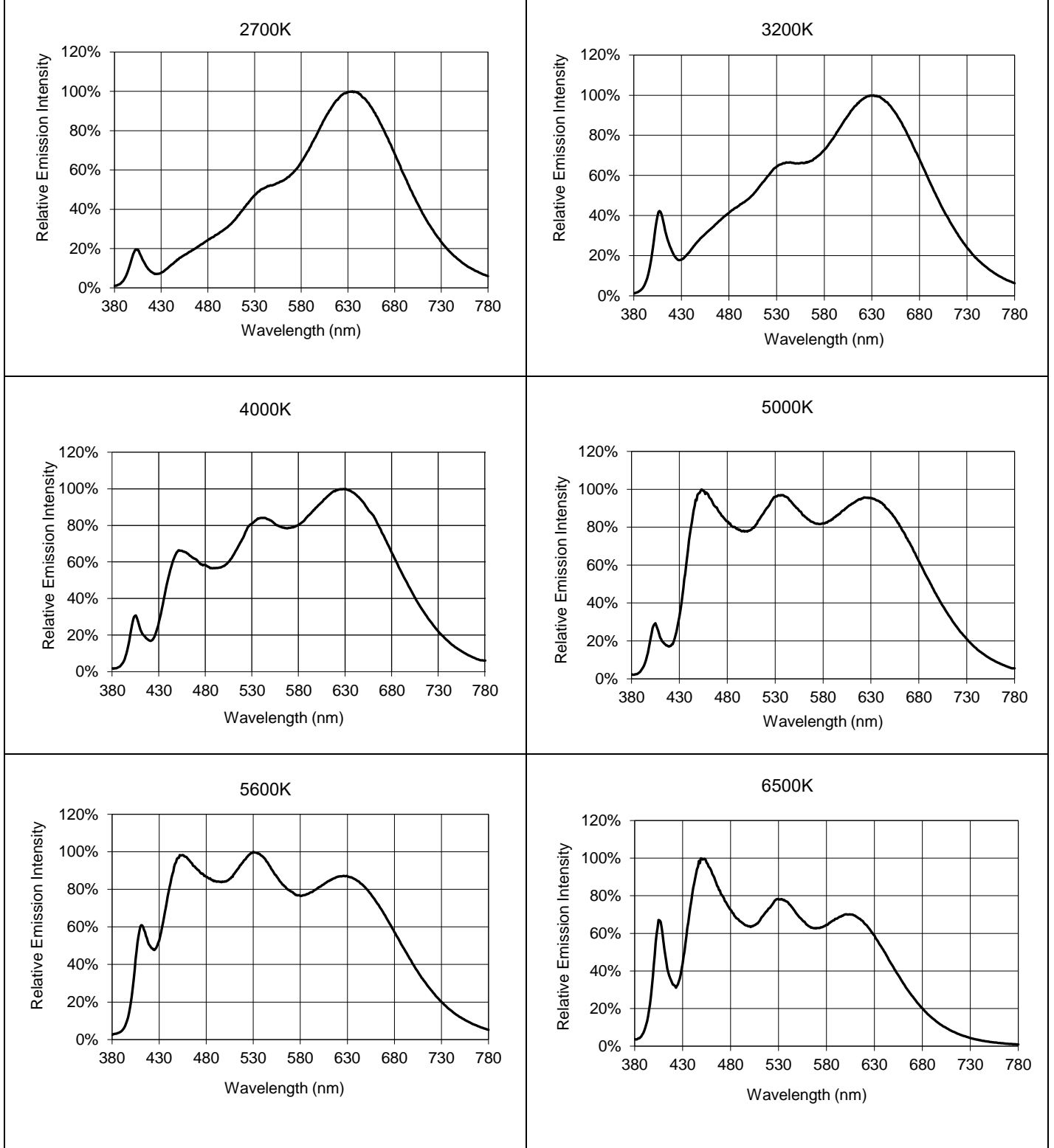

REFLOW PROFILE

SOLDERING RAMP-UP TIME (Pb-FREE)

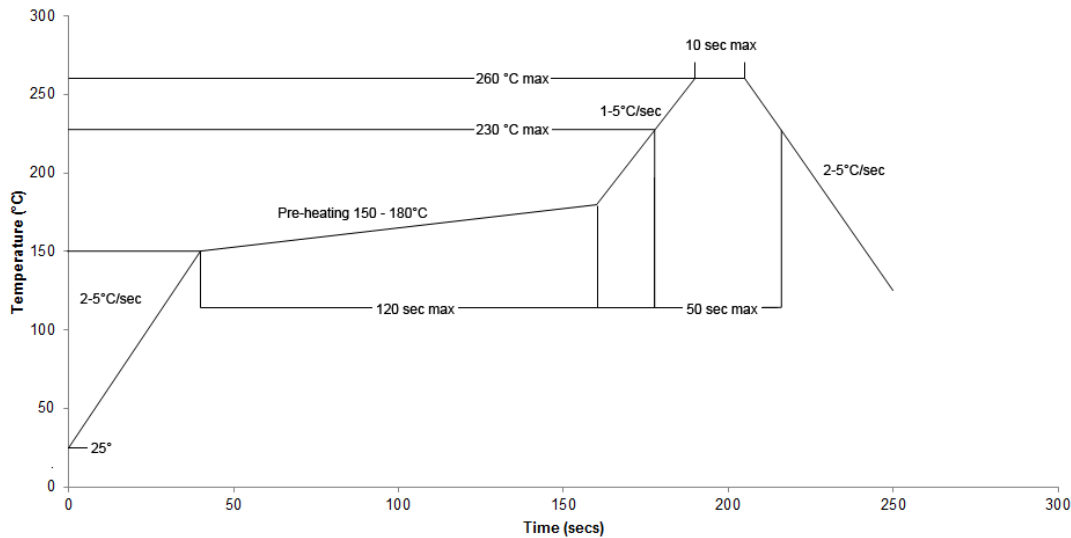

NOTE: Soldering paste with the melting point at 230°C is recommended.

INSTRUCTIONS FOR SMT

Problems caused by improper selection of collet

Choosing the right collet is important in ensuring product quality after SMT. LEDs are different from other electronic components, as they are not only concerned with electrical output but also optical output. This characteristic makes LEDs more fragile in the process of SMT. If the collet's lowering height is not well set, it will bring damage to the gold wire at the time of collet's pick-and-place process which can cause the LED to not illuminate, flicker or contribute to other quality problems, some of which may not be immediately detectable.

Collet selection

During SMT, please choose the collet that has larger outer diameter than the lighting area of lens, in order to avoid damage the gold wire inside the LED. Different collets fit for different products, please refer to the following figures below.



Setting the height of the collet is crucial in order to avoid damage to the top view SMD. If the collet setting is set to too low of an altitude, the collet will press down on the SMD, causing damage or breakage to the encapsulant and cause distortion or breakage of the gold wire.

Other notes of caution:

- No pressure should be exerted to the epoxy shell of the SMD under high temperature.
- Do not scratch or wipe the lens since the lens and gold wire inside are rather fragile and cross out easy to break.
- LED should be used as soon as possible when being taken out of the original package, and should be stored in anti-moisture and anti-ESD package.
- This usage and handling instructions are for reference only.

TAPE SPECIFICATIONS

TAPE DIMENSIONS (UNIT: MM)

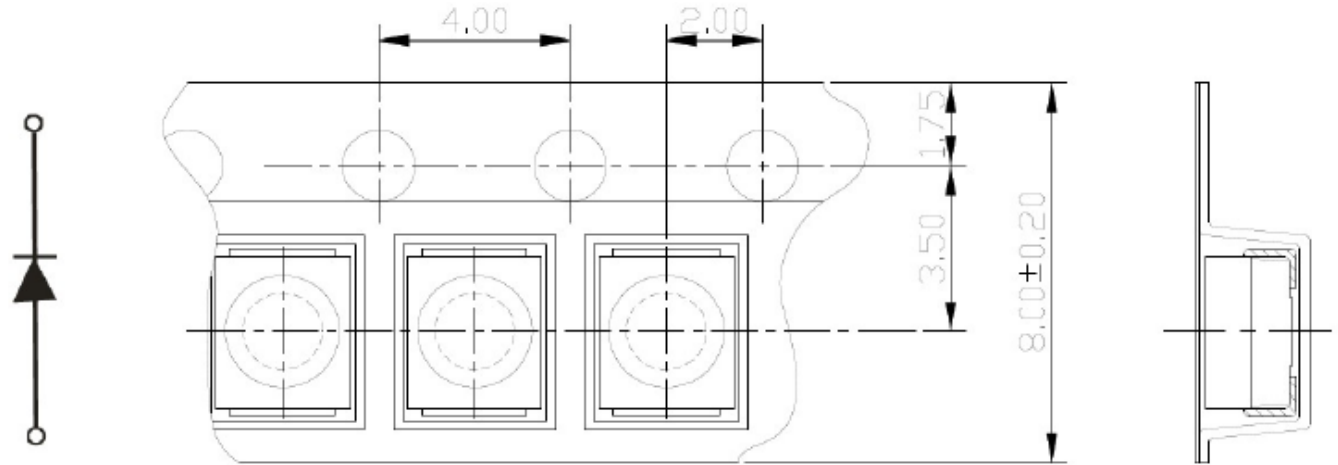

All dimensions in mm, tolerance unless mentioned is ±0.1mm.

TAPE LAYOUT (NOT DRAWN TO SCALE)

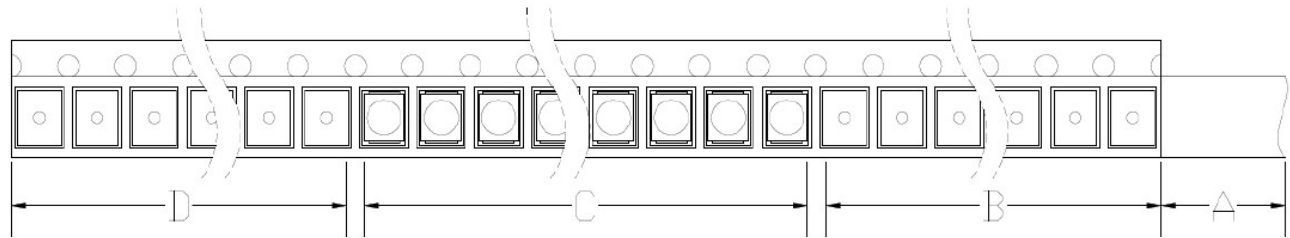

- A: COVER TAPE, 300 MM;
- B: EMPTY LEADER, 200 MM;
- C: LED, 5000 PCS;
- D: EMPTY TRAILER, 200 MM.

REEL SPECIFICATIONS

REEL DIMENSIONS TOP (UNIT: MM)

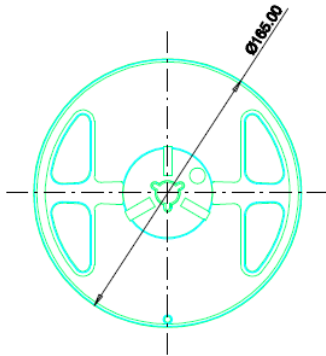

REEL DIMENSIONS BOTTOM (UNIT: MM)

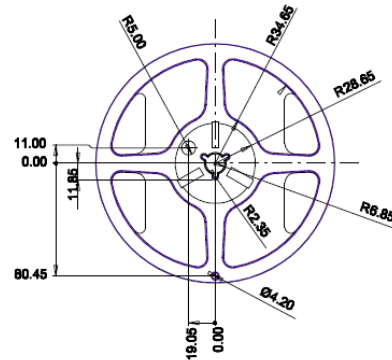

REEL DIMENSIONS SIDE (UNIT: MM)

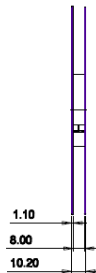

FEEDING DIRECTION

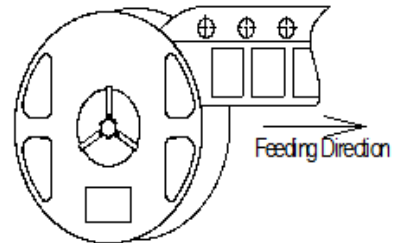

LOT NUMBERING SCHEME

Yuji LED uses two formats for lot numbering purposes:

1) YYYY-MM-XXX-Z

YYYY: 4-digit manufacturing year
MM: 2-digit manufacturing month
XXX: 3-digit inventory number (000 – 999)
Z: internal alphanumeric code

2) YYYYMMXXX

YYYY: 4-digit manufacturing year
MM: 2-digit manufacturing month
XXX: 3-digit inventory number (000 – 999)

SHIPPING INFORMATION

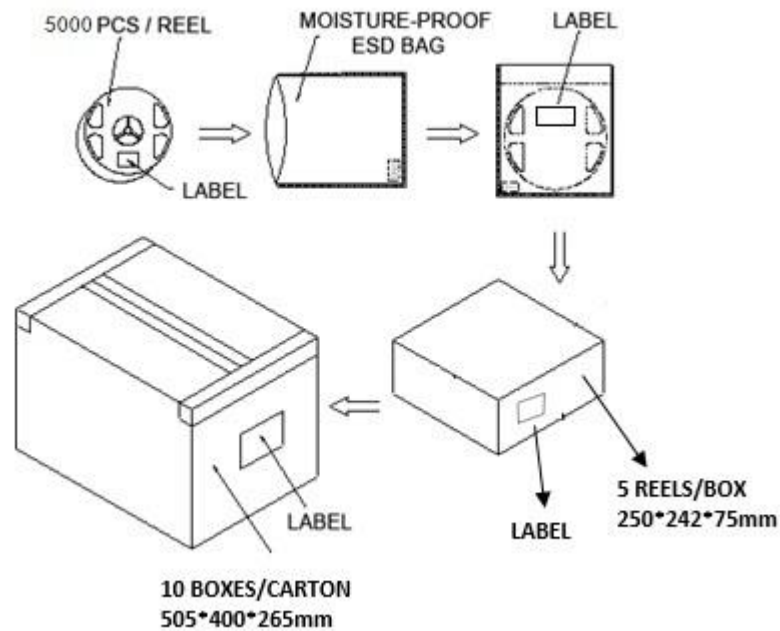

NOTES:

1. Reeled products (max 5,000 pcs / reel) are packed in a moisture-proof bag along with a moisture desiccant pack.
2. Each inner box contains up to 5 moisture-proof bag (total maximum number of SMDs is 25,000pcs). Box package size: 246 mm x 225 mm x 76 mm.
3. Each outer package contains 10 inner boxes. Box size: 490 mm x 400 mm x 262 mm.
4. Outer package is sealed with protective bubble wrap and foam. (Part numbers, lot numbers, quantity should appear on the label on the moisture-proof bag, part numbers).
5. This packaging merely intended as a reference for standard quantity orders only – please note that actual packaging can differ depending on the order circumstances.