

PRODUCT:

3030 SURFACE MOUNT LED



FEATURES:

3.0 mm x 3.0 mm x 0.52 mm surface-mount LED
120° emission angle

DESCRIPTION

YUJILEDS® Spectrum^X series LED provides the flexibility on tuning dynamic spectrum for achieving high CRI or required spectra for any specific application. This mid-power LED can be used in a variety of applications demanding high color quality and performance.



ELECTRICAL-OPTICAL CHARACTERISTICS (T _A = 25 °C)							
PARAMETER	SYMBOL	VALUE			UNIT	TOLERANCE	CONDITION
		MIN.	TYP.	MAX.			
Forward voltage	V _f	3.0	--	3.4	V	±0.05	I _f = 300mA
Luminous flux	Φ _v	12	--	16	lm	--	I _f = 300mA
Dominant wavelength	λ _D	--	625	--	nm	±5	I _f = 300mA
Chromaticity coordinates	(X,Y)	--	(0.696, 0.299)	--	--	--	I _f = 300mA
Reverse current	I _r	--	--	10	μA	±0.1	V _r = 5V
Viewing angle	2θ _{1/2}	--	120	--	Deg	±5	I _f = 300mA

ABSOLUTE MAXIMUM RATING (T _A = 25 °C)			
PARAMETER	SYMBOL	LIMIT	UNIT
Power Consumption	P _D	1350	mW
DC Forward Current (pulsed)*	I _{Fp}	600**	mA
DC Forward Current	I _F	400	mA
Reverse Voltage	V _R	5	V
Junction Temperature	T _j	125	°C
Solder Point Temperature***	T _s	105	°C
Operating Temperature	T _{opr}	-40 ~ +85	°C
Storage Temperature	T _{stg}	-30 ~ +85	°C
Soldering Temperature	T _{sol}	260 ± 5	°C
Reflow Cycles Allowed	--	2	--

* Pulse width ≤ 0.1ms, Duty ≤ 1/10.

** Theoretical data.

*** See page 2 for solder point definition.

PACKAGE LAYOUT

Tolerance is $\pm 0.1\text{mm}$ unless otherwise noted.

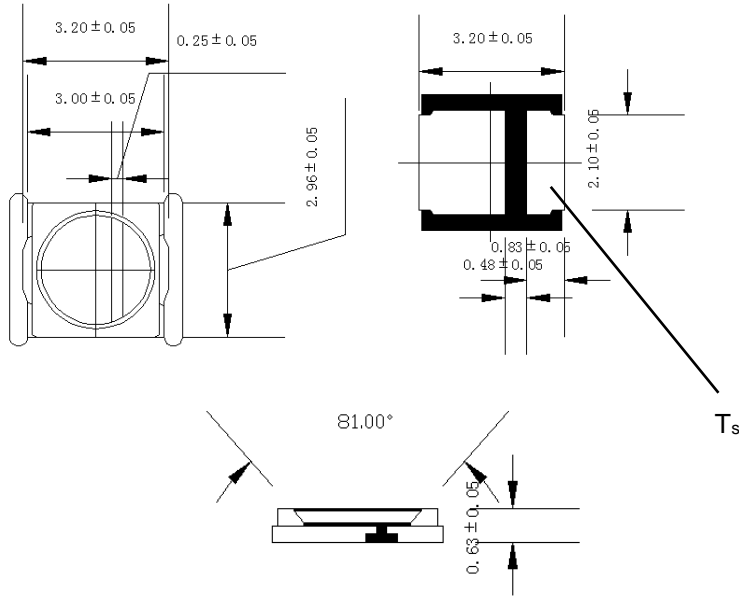

PACKAGE MATERIALS

ITEM	DESCRIPTION
DIE MATERIAL	InGaN
LEAD FRAME MATERIAL	PCT
ENCAPSULANT RESIN MATERIAL	SILICONE + PHOSPHOR
ELECTRODES MATERIAL	SILVER-PLATED COPPER

VOLTAGE BIN CODES

Bin	V30	V31	V32	V33
V_F	3.0-3.1	3.1-3.2	3.2-3.3	3.3-3.4

RECOMMENDED SOLDER PAD LAYOUT

Tolerance is $\pm 0.1\text{mm}$ unless otherwise noted.

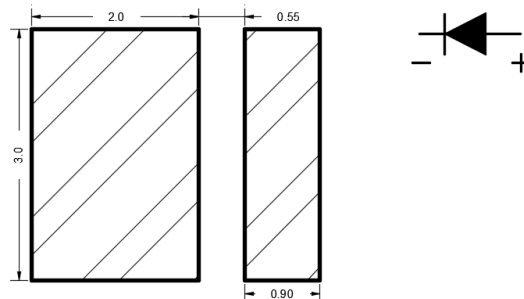

CHROMATICITY BINS & COORDINATES								
BIN	CIE 1931 COORDINATES							
	X0	Y0	X1	Y1	X2	Y2	X3	Y3
	0.6933	0.3030	0.6933	0.2980	0.6973	0.2980	0.6973	0.3030

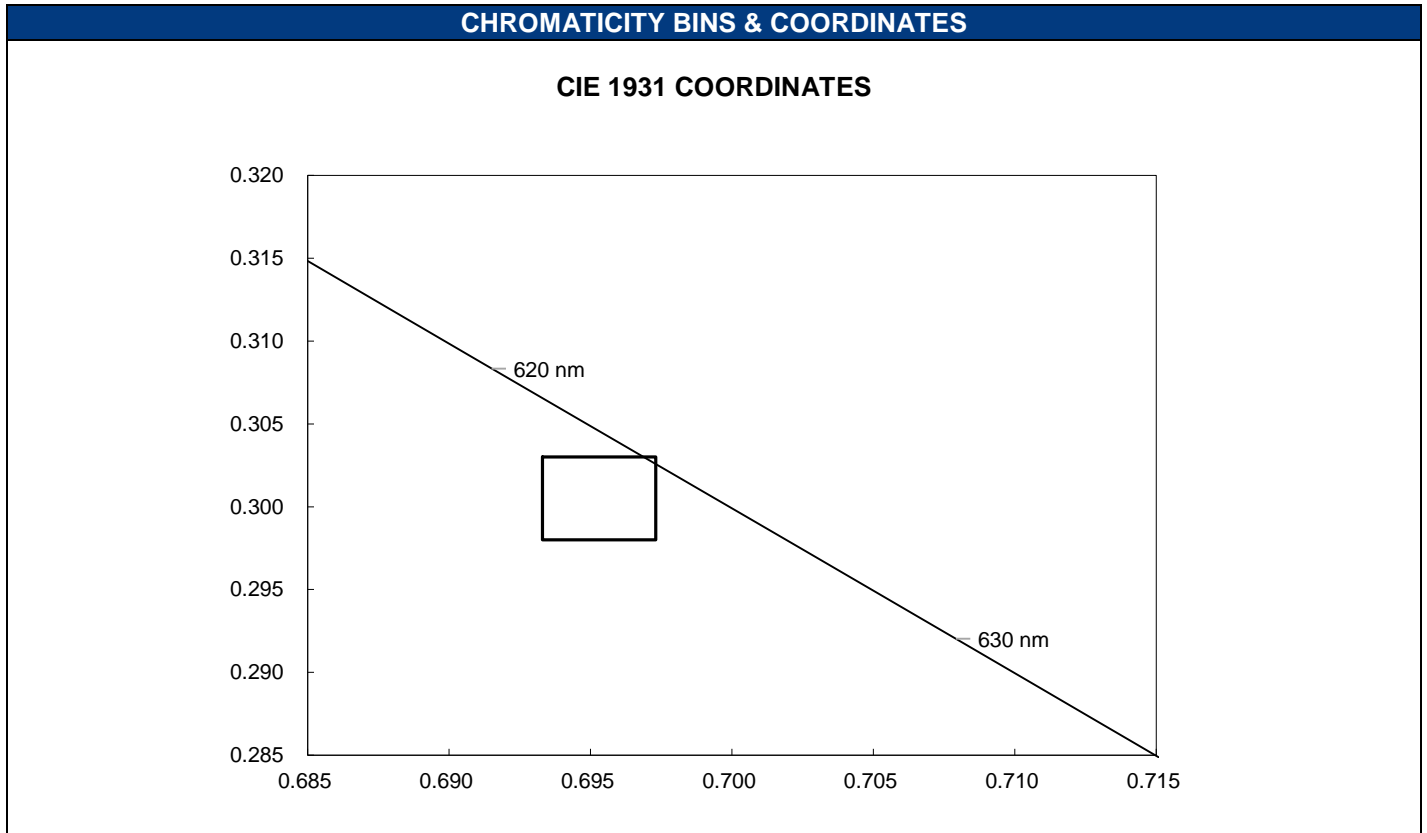

CHARACTERISTIC CURVES

ALL CHARACTERISTIC CURVES ARE FOR REFERENCE ONLY AND NOT GUARANTEED

FORWARD CURRENT VS FORWARD VOLTAGE ($T_A = 25^\circ\text{C}$)

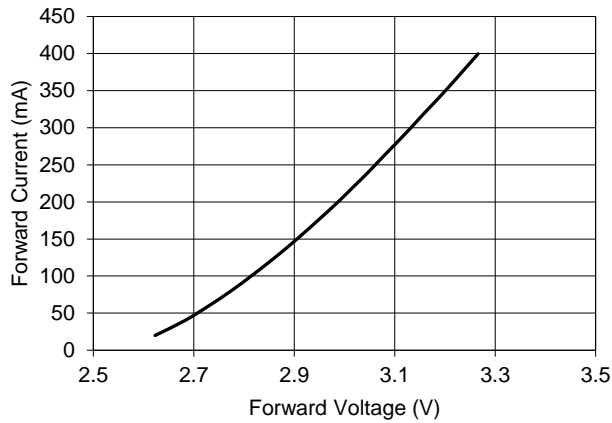

FORWARD CURRENT VS RELATIVE LUMINOUS OUTPUT ($T_A = 25^\circ\text{C}$)

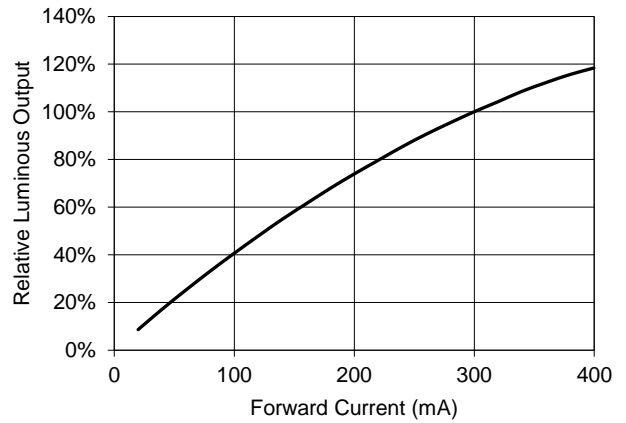

SOLDER POINT TEMPERATURE VS FORWARD VOLTAGE ($I_F = 300\text{ mA}$)

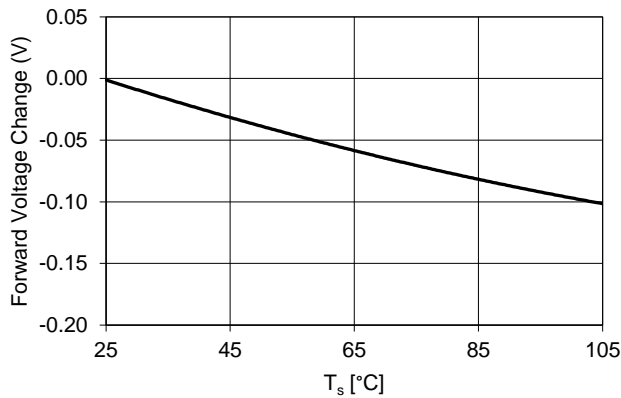

SOLDER POINT TEMPERATURE VS RELATIVE LUMINOUS OUTPUT ($I_F = 300\text{ mA}$)

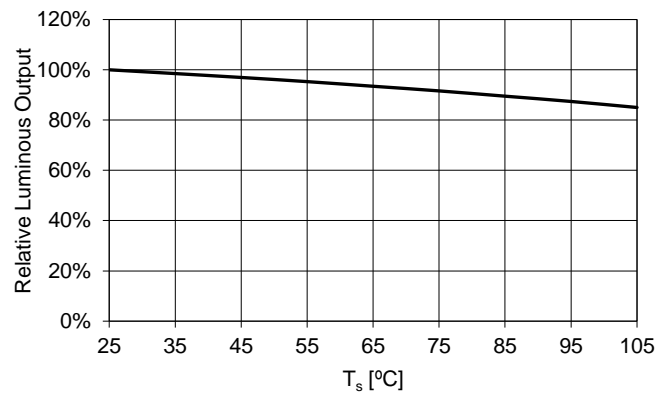

FORWARD CURRENT VS CHROMATICITY SHIFT ($T_A = 25^\circ\text{C}$)

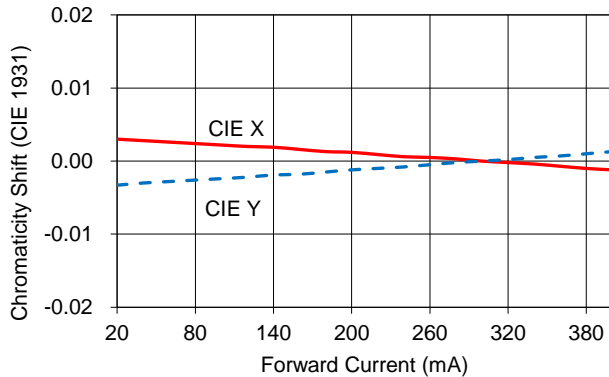

SOLDER POINT TEMPERATURE VS CHROMATICITY SHIFT ($I_F = 300\text{ mA}$)

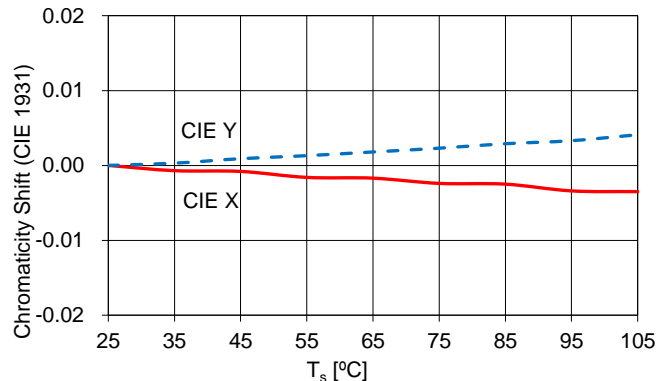

CHARACTERISTIC CURVES (CONTINUED)

FORWARD CURRENT DERATING BASED ON SOLDER POINT POINT

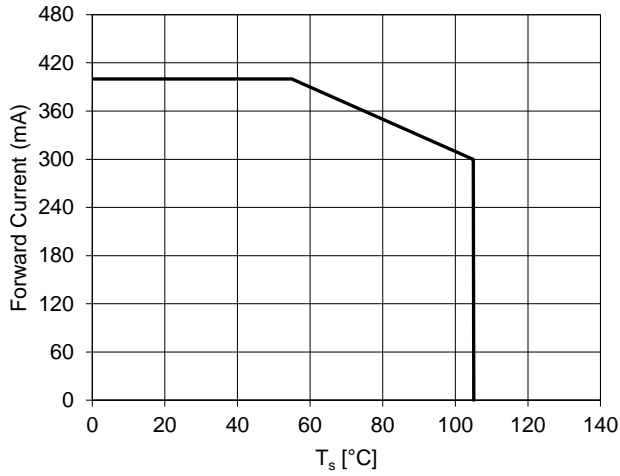

NOTE: DE-RATING CURVES ARE MEANT FOR RECOMMENDATION ONLY AND ARE NOT MEANT TO PROVIDE GUARANTEES OF PRODUCT STABILITY AND LONGEVITY

TYPICAL SPATIAL DISTRIBUTION (TA = 25°C, IF = 300 mA)

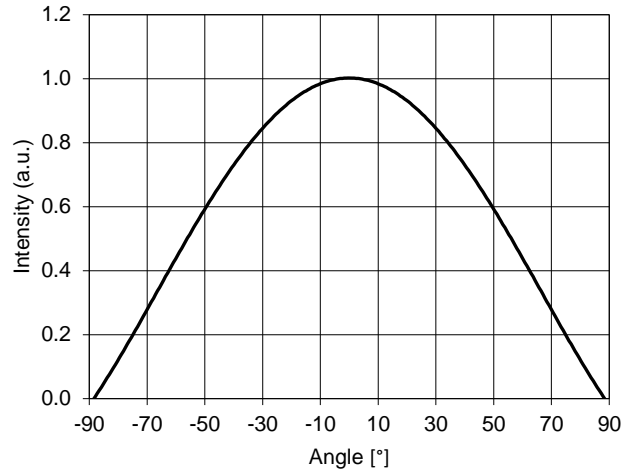

TYPICAL SPECTRAL DISTRIBUTION GRAPHS

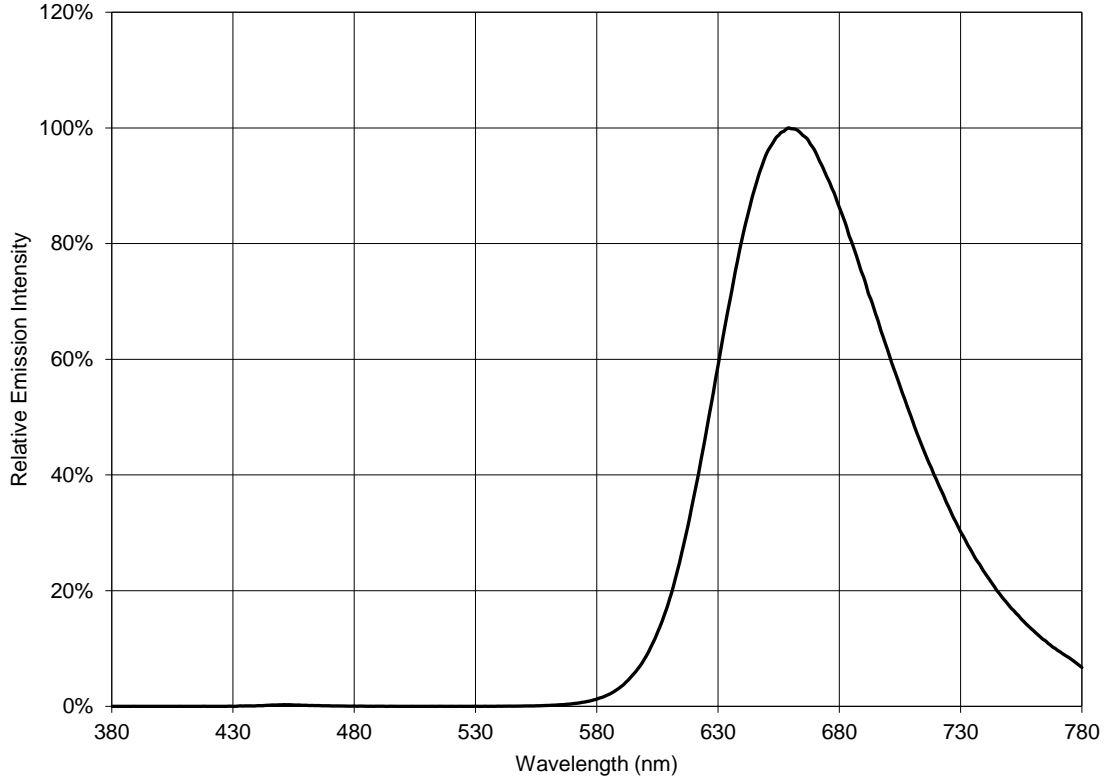

REFLOW PROFILE

SOLDERING RAMP-UP TIME (Pb-FREE)

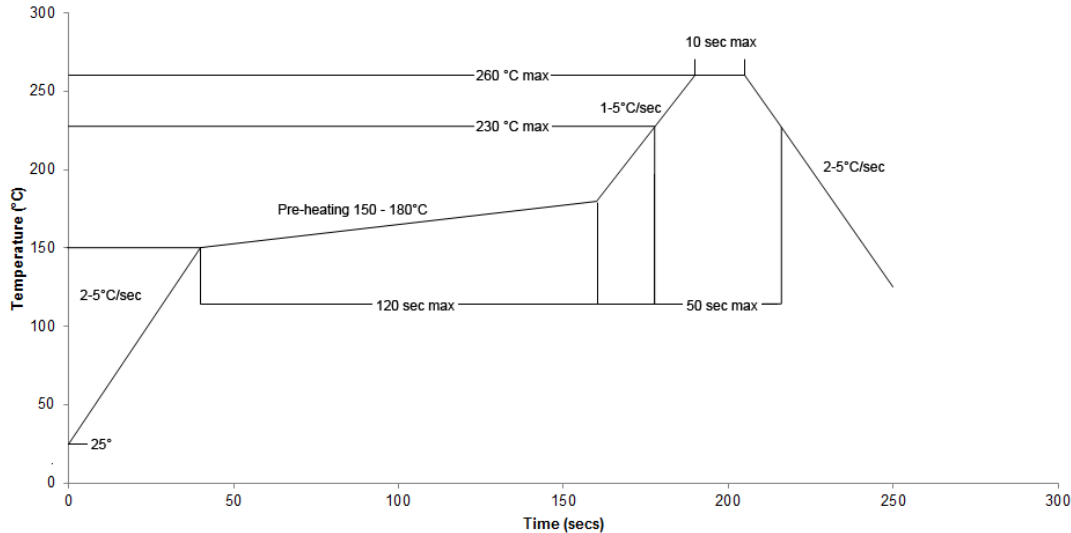

NOTE: Soldering paste with the melting point at 230°C is recommended

INSTRUCTIONS FOR SMT

Problems caused by improper selection of collet

Choosing the right collet is important in ensuring product quality after SMT. LEDs are different from other electronic components, as they are not only concerned with electrical output but also optical output. This characteristic makes LEDs more fragile in the process of SMT. If the collet's lowering height is not well set, it will bring damage to the gold wire at the time of collet's pick-and-place process which can cause the LED to not illuminate, flicker or contribute to other quality problems, some of which may not be immediately detectable.

Collet selection

During SMT, please choose the collet that has larger outer diameter than the lighting area of lens, in order to avoid damage the gold wire inside the LED. Different collets fit for different products, please refer to the following figures below.



Setting the height of the collet is crucial in order to avoid damage to the top view SMD. If the collet setting is set to too low of an altitude, the collet will press down on the SMD, causing damage or breakage to the encapsulant and cause distortion or breakage of the gold wire.

Other notes of caution:

- No pressure should be exerted to the epoxy shell of the SMD under high temperature.
- Do not scratch or wipe the lens since the lens and gold wire inside are rather fragile and cross out easy to break.
- LED should be used as soon as possible when being taken out of the original package, and should be stored in anti-moisture and anti-ESD package.
- This usage and handling instructions are for reference only.

TAPE SPECIFICATIONS

TAPE DIMENSIONS (UNIT: MM)

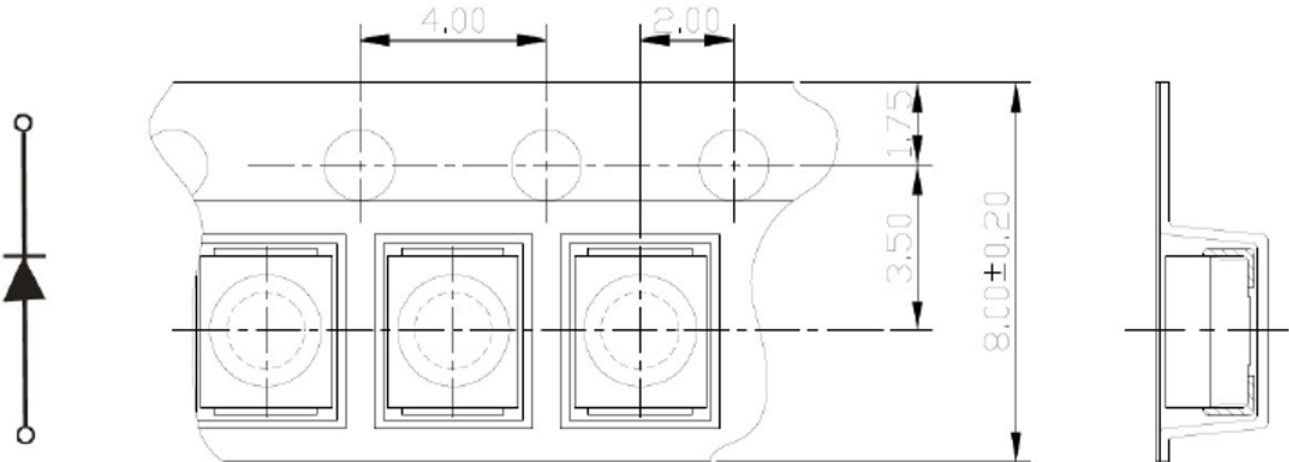

All dimensions in mm, tolerance unless mentioned is ± 0.1 mm.

TAPE LAYOUT (NOT DRAWN TO SCALE)

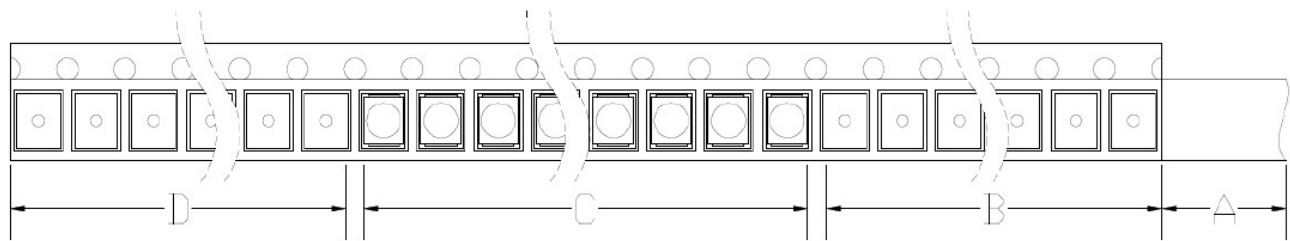

- A: COVER TAPE, 300 MM;
- B: EMPTY LEADER, 200 MM;
- C: LED, 3000 PCS;
- D: EMPTY TRAILER, 200 MM;

REEL SPECIFICATIONS

REEL DIMENSIONS TOP (UNIT: MM)

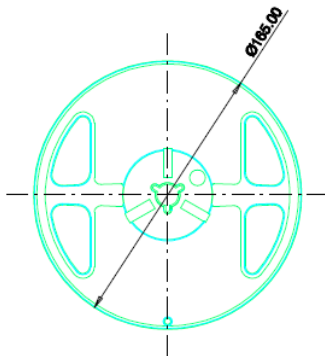

REEL DIMENSIONS BOTTOM (UNIT: MM)

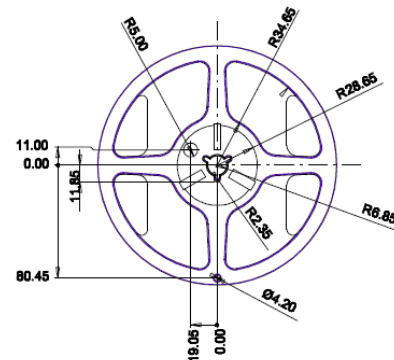

REEL DIMENSIONS SIDE (UNIT: MM)

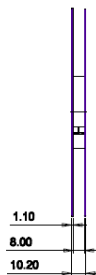

FEEDING DIRECTION

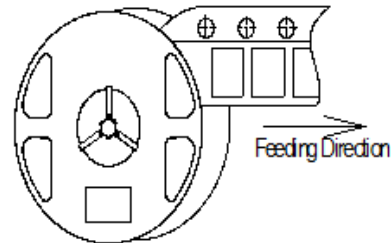

LOT NUMBERING SCHEME

Yuji LED uses two formats for lot numbering purposes:

1) YYYY-MM-XXX-Z

YYYY: 4-digit manufacturing year
MM: 2-digit manufacturing month
XXX: 3-digit inventory number (000 – 999)
Z: internal alphanumeric code

2) YYYYMMXXX

YYYY: 4-digit manufacturing year
MM: 2-digit manufacturing month
XXX: 3-digit inventory number (000 – 999)

SHIPPING INFORMATION

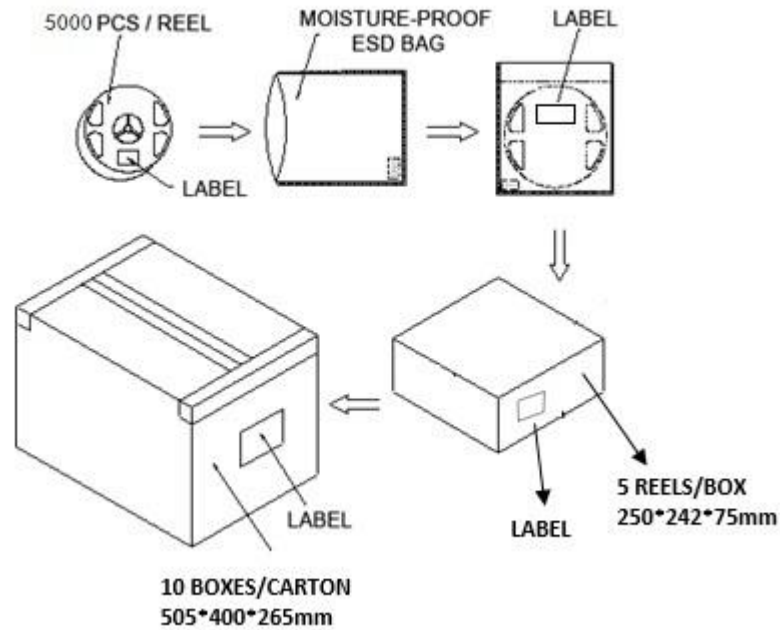

NOTES:

1. Reeled products (max 5,000 pcs / reel) are packed in a moisture-proof bag along with a moisture desiccant pack.
2. Each inner box contains up to 5 moisture-proof bag (total maximum number of SMDs is 25,000pcs). Box package size: 246 mm x 225 mm x 76 mm.
3. Each outer package contains 10 inner boxes. Box size: 490 mm x 400 mm x 262 mm.
4. Outer package is sealed with protective bubble wrap and foam. (Part numbers, lot numbers, quantity should appear on the label on the moisture-proof bag, part numbers).
5. This packaging merely intended as a reference for standard quantity orders only – please note that actual packaging can differ depending on the order circumstances.