

### PRODUCT:

3030 SURFACE MOUNT LED

### FEATURES:

3.0 mm × 3.0 mm × 0.52 mm surface-mount LED  
 120° emission angle  
 95 min Ra



### DESCRIPTION

YUJILEDS® BC Series high CRI 3030 SMD provides a no-compromise high CRI, high efficacy solution in an industry standard PCT package. Providing 95 CRI (min), this mid-power LED can be used in a variety of applications demanding high color quality and performance.



ELECTRICAL-OPTICAL CHARACTERISTICS (T <sub>A</sub> = 25 °C)							
PARAMETER	SYMBOL	VALUE			UNIT	TOLERANCE	CONDITION
		MIN.	TYP.	MAX.			
Forward voltage	V <sub>f</sub>	3.0	--	3.4	V	±0.05	I <sub>f</sub> = 300mA
Luminous flux	Φ <sub>2700K</sub>	73	--	79	lm	--	I <sub>f</sub> = 300mA
	Φ <sub>3200K</sub>	81		87			
	Φ <sub>4000K</sub>	90		98			
	Φ <sub>5000K</sub>	94		100			
	Φ <sub>5600K</sub>	94		100			
	Φ <sub>6500K</sub>	96		102			
Correlated color temperature	CCT <sub>2700K</sub>	2550	2700	2850	K	--	I <sub>f</sub> = 300mA
	CCT <sub>3200K</sub>	3050	3200	3350			
	CCT <sub>4000K</sub>	3800	4000	4200			
	CCT <sub>5000K</sub>	4700	5000	5300			
	CCT <sub>5600K</sub>	5300	5600	5900			
	CCT <sub>6500K</sub>	6000	6500	7000			
Color rendering index	Ra*	95	--	--	--	±1	I <sub>f</sub> = 300mA
TCS R9 (CRI Red)	R9	--	90	--	--	--	I <sub>f</sub> = 300mA
Chromaticity coordinates	(X,Y)**	--	--	--	--	±0.005	--
Reverse current	I <sub>r</sub>	--	--	10	μA	±0.1	V <sub>r</sub> = 5V
Viewing angle	2θ1/2	--	120	--	Deg	±5	I <sub>f</sub> = 300mA

\*Ra minimum 93 at 6500K.

\*\*Yuji Everfine standard equipment shall prevail.



ORDERING INFORMATION			
PART NUMBER	CCT	CHROMATICITY BINS	VOLTAGE RANGE
YJ-BC-3030-G02-27	2700K ± 150K	27L, 27R	0.1 V
YJ-BC-3030-G02-32	3200K ± 150K	32L, 32R	0.1 V
YJ-BC-3030-G02-40	4000K ± 200K	40L, 40R	0.1 V
YJ-BC-3030-G02-50	5000K ± 300K	50L, 50R	0.1 V
YJ-BC-3030-G02-56	5600K ± 300K	56L, 56R	0.1 V
YJ-BC-3030-G02-65	6500K ± 500K	65L, 65R	0.1 V
YJ-BC-3030-G02-XX	CUSTOM		

VOLTAGE BIN CODES				
Bin	V30	V31	V32	V33
V <sub>F</sub>	3.0-3.1	3.1-3.2	3.2-3.3	3.3-3.4

ABSOLUTE MAXIMUM RATING (T <sub>A</sub> = 25 °C)			
PARAMETER	SYMBOL	LIMIT	UNIT
Power Consumption	P <sub>D</sub>	1350	mW
DC Forward Current (pulsed)*	I <sub>Fp</sub>	600**	mA
DC Forward Current	I <sub>F</sub>	400	mA
Reverse Voltage	V <sub>R</sub>	5	V
Junction Temperature	T <sub>j</sub>	125	°C
Solder Point Temperature***	T <sub>s</sub>	105	°C
Operating Temperature	T <sub>opr</sub>	-40 ~ +85	°C
Storage Temperature	T <sub>stg</sub>	-30 ~ +85	°C
Soldering Temperature	T <sub>sol</sub>	260 ± 5	°C
Reflow Cycles Allowed	--	2	--

\* Pulse width ≤ 0.1ms, Duty ≤ 1/10.

\*\* Theoretical data.

\*\*\* See page 4 for solder point definition.

CHROMATICITY BINS & COORDINATES									
CCT	BIN	CIE 1931 COORDINATES							
		X0	Y0	X1	Y1	X2	Y2	X3	Y3
6500K	65L	0.3067	0.3235	0.3088	0.3121	0.3143	0.3178	0.3128	0.3295
	65R	0.3128	0.3295	0.3143	0.3178	0.3205	0.3241	0.3192	0.3359
5600K	56L	0.3237	0.3401	0.3243	0.3269	0.3303	0.3320	0.3300	0.3460
	56R	0.3300	0.3460	0.3303	0.3320	0.3370	0.3378	0.3372	0.3526
5000K	50L	0.3372	0.3526	0.3370	0.3378	0.3444	0.3440	0.3456	0.3592
	50R	0.3456	0.3592	0.3444	0.3440	0.3501	0.3487	0.3517	0.3637
4000K	40L	0.3737	0.3793	0.3703	0.3633	0.3784	0.3687	0.3824	0.3847
	40R	0.3824	0.3847	0.3784	0.3687	0.3873	0.3742	0.3921	0.3902
3200K	32L	0.4194	0.4042	0.4130	0.3882	0.4201	0.3909	0.4269	0.4069
	32R	0.4269	0.4069	0.4201	0.3909	0.4275	0.3935	0.4347	0.4095
2700K	27L	0.4542	0.4166	0.4459	0.4005	0.4552	0.4025	0.4642	0.4185
	27R	0.4642	0.4185	0.4552	0.4025	0.4652	0.4043	0.4749	0.4203

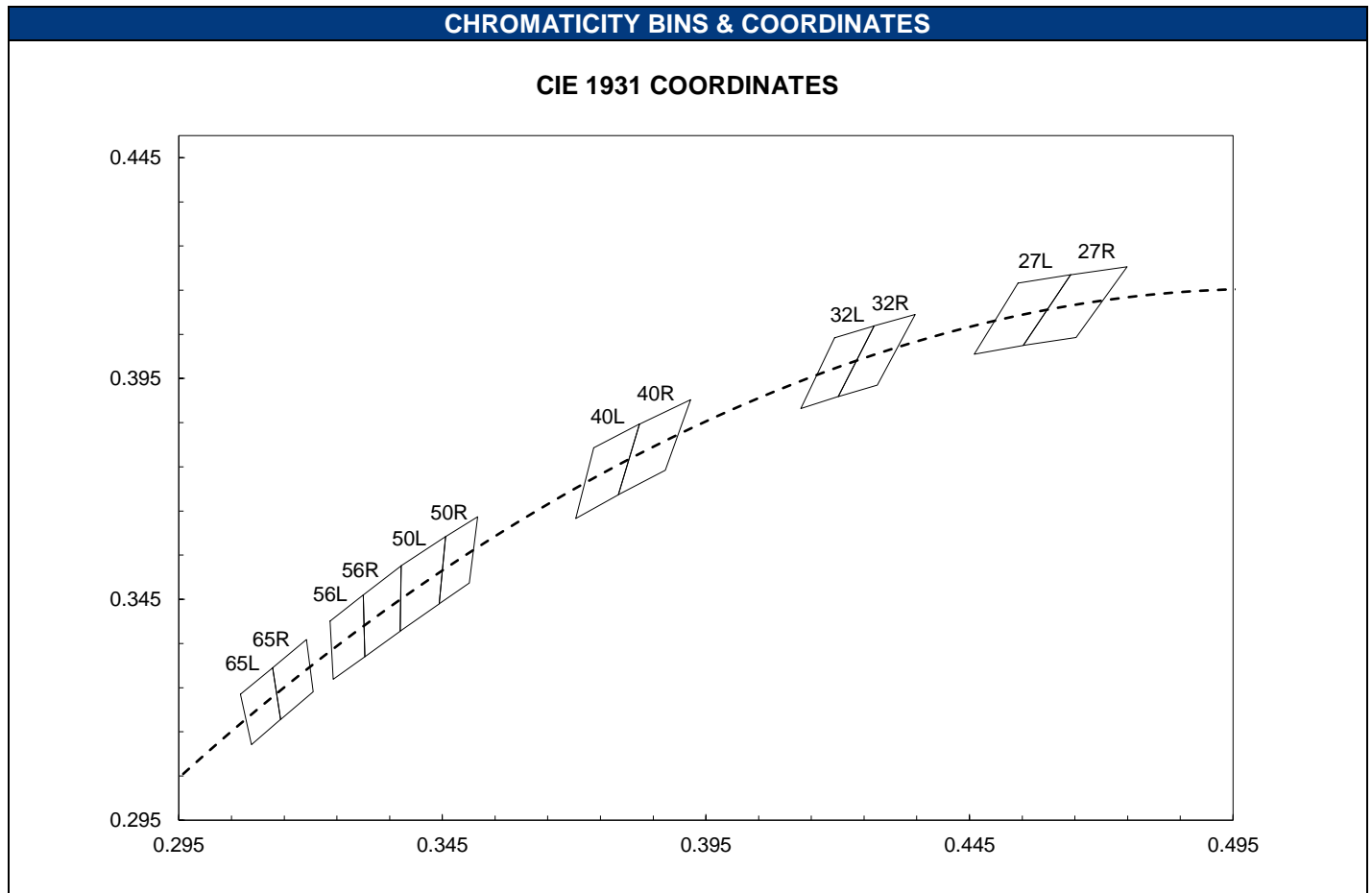

**PACKAGE LAYOUT**

Tolerance is  $\pm 0.1\text{mm}$  unless otherwise noted.

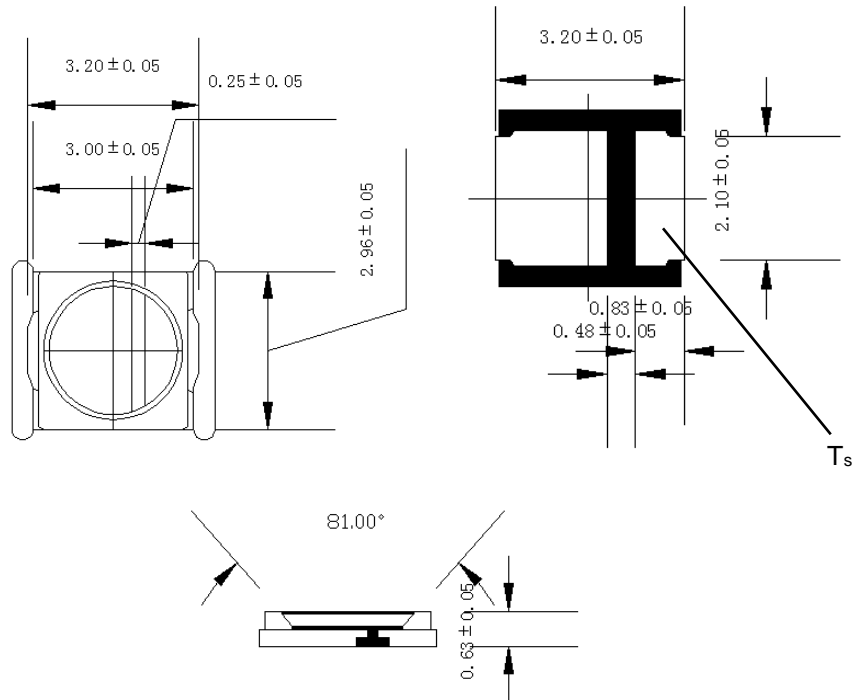

**PACKAGE MATERIALS**

ITEM	DESCRIPTION
DIE MATERIAL	InGaN
LEAD FRAME MATERIAL	PCT
ENCAPSULANT RESIN MATERIAL	SILICONE + PHOSPHOR
ELECTRODES MATERIAL	SILVER-PLATED COPPER

**RECOMMENDED SOLDER PAD LAYOUT**

Tolerance is  $\pm 0.1\text{mm}$  unless otherwise noted.

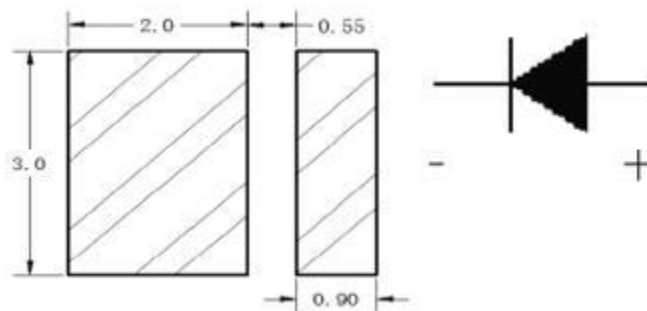

**CHARACTERISTIC CURVES**

ALL CHARACTERISTIC CURVES ARE FOR REFERENCE ONLY AND NOT GUARANTEED

**FORWARD CURRENT VS FORWARD VOLTAGE ( $T_A = 25^\circ\text{C}$ )**

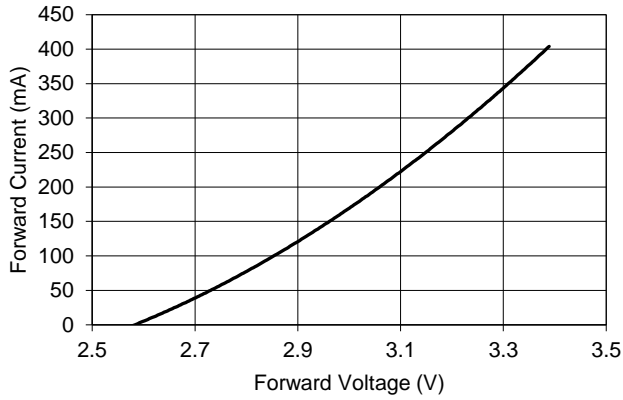

**FORWARD CURRENT VS RELATIVE LUMINOUS OUTPUT ( $T_A = 25^\circ\text{C}$ )**

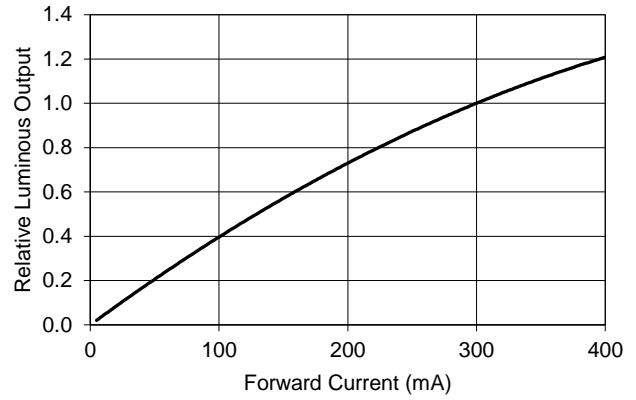

**SOLDER POINT TEMPERATURE VS FORWARD VOLTAGE ( $I_F = 300\text{ mA}$ )**

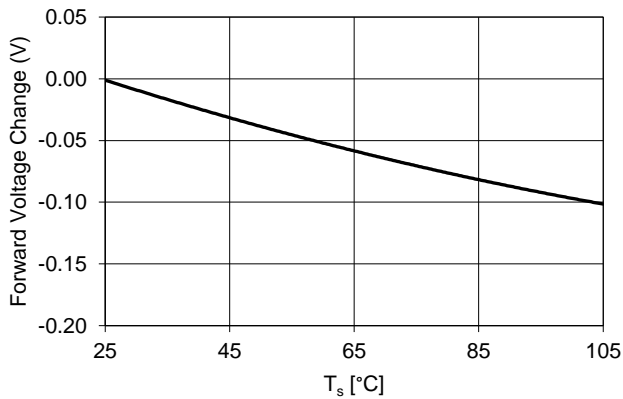

**SOLDER POINT TEMPERATURE VS RELATIVE LUMINOUS OUTPUT ( $I_F = 300\text{ mA}$ )**

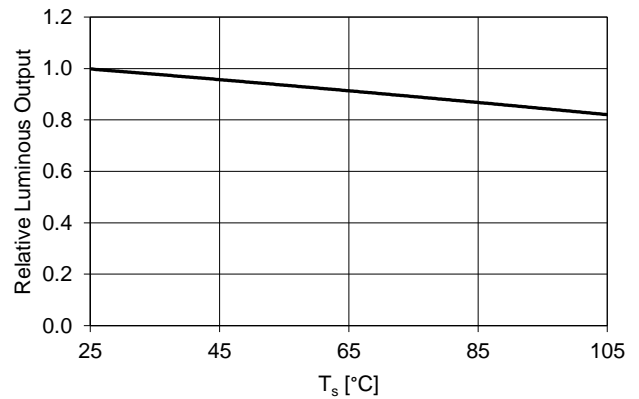

**FORWARD CURRENT VS CHROMATICITY SHIFT (4000K,  $T_A = 25^\circ\text{C}$ )**

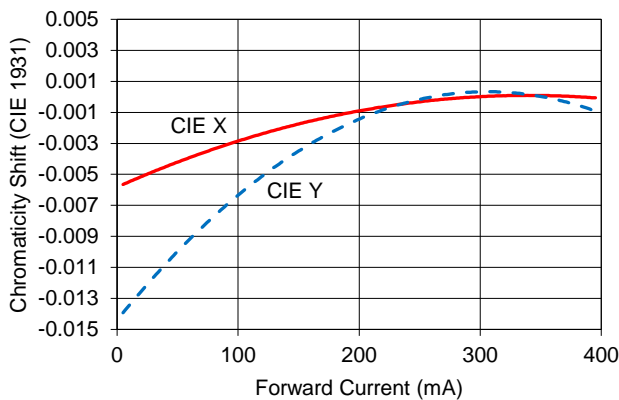

**FORWARD CURRENT VS CHROMATICITY SHIFT (4000K,  $T_A = 25^\circ\text{C}$ )**

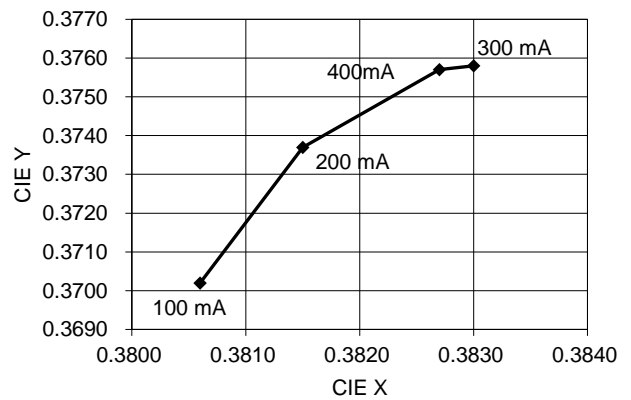

**CHARACTERISTIC CURVES (CONTINUED)**

SOLDER POINT TEMPERATURE VS CHROMATICITY (4000K,  $I_F = 300$  mA)

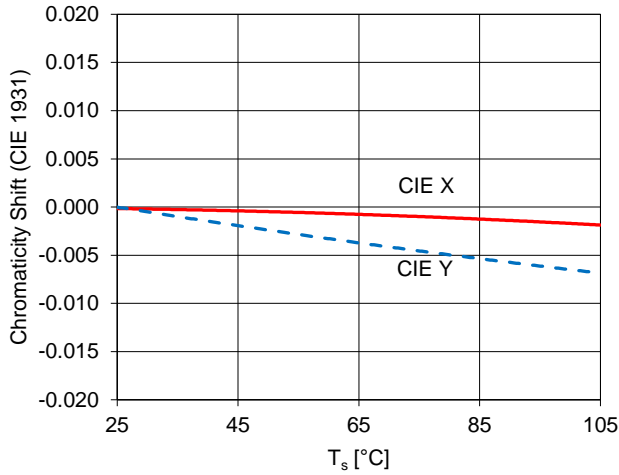

SOLDER POINT TEMPERATURE VS CHROMATICITY (4000K,  $I_F = 300$  mA)

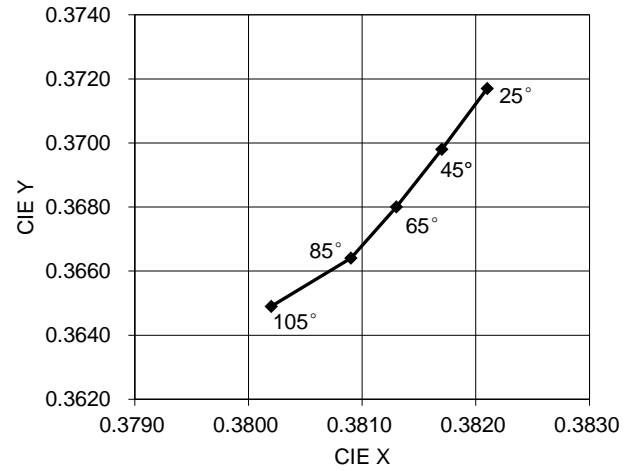

FORWARD CURRENT DERATING BASED ON SOLDER POINT

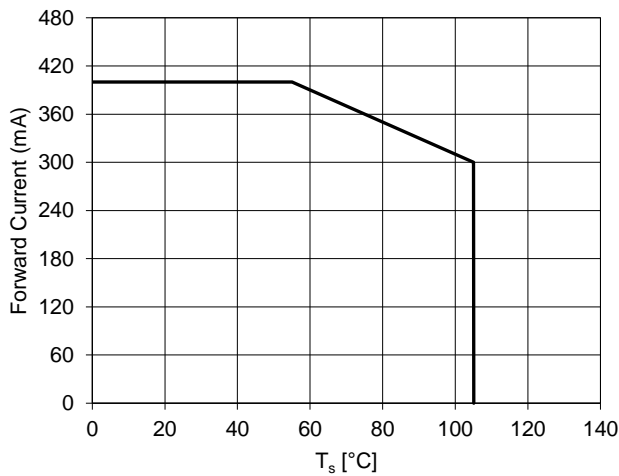

NOTE: DE-RATING CURVES ARE MEANT FOR RECOMMENDATION ONLY AND ARE NOT MEANT TO PROVIDE GUARANTEES OF PRODUCT STABILITY AND LONGEVITY

TYPICAL SPATIAL DISTRIBUTION ( $T_A = 25^\circ\text{C}$ ,  $I_F = 300$  mA)

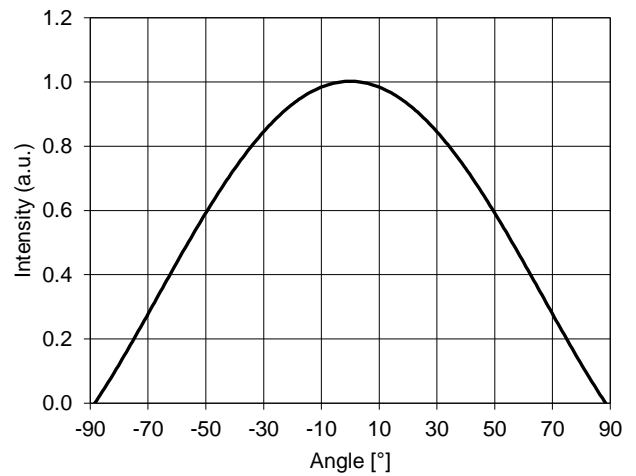

**TYPICAL SPECTRAL DISTRIBUTION GRAPHS**

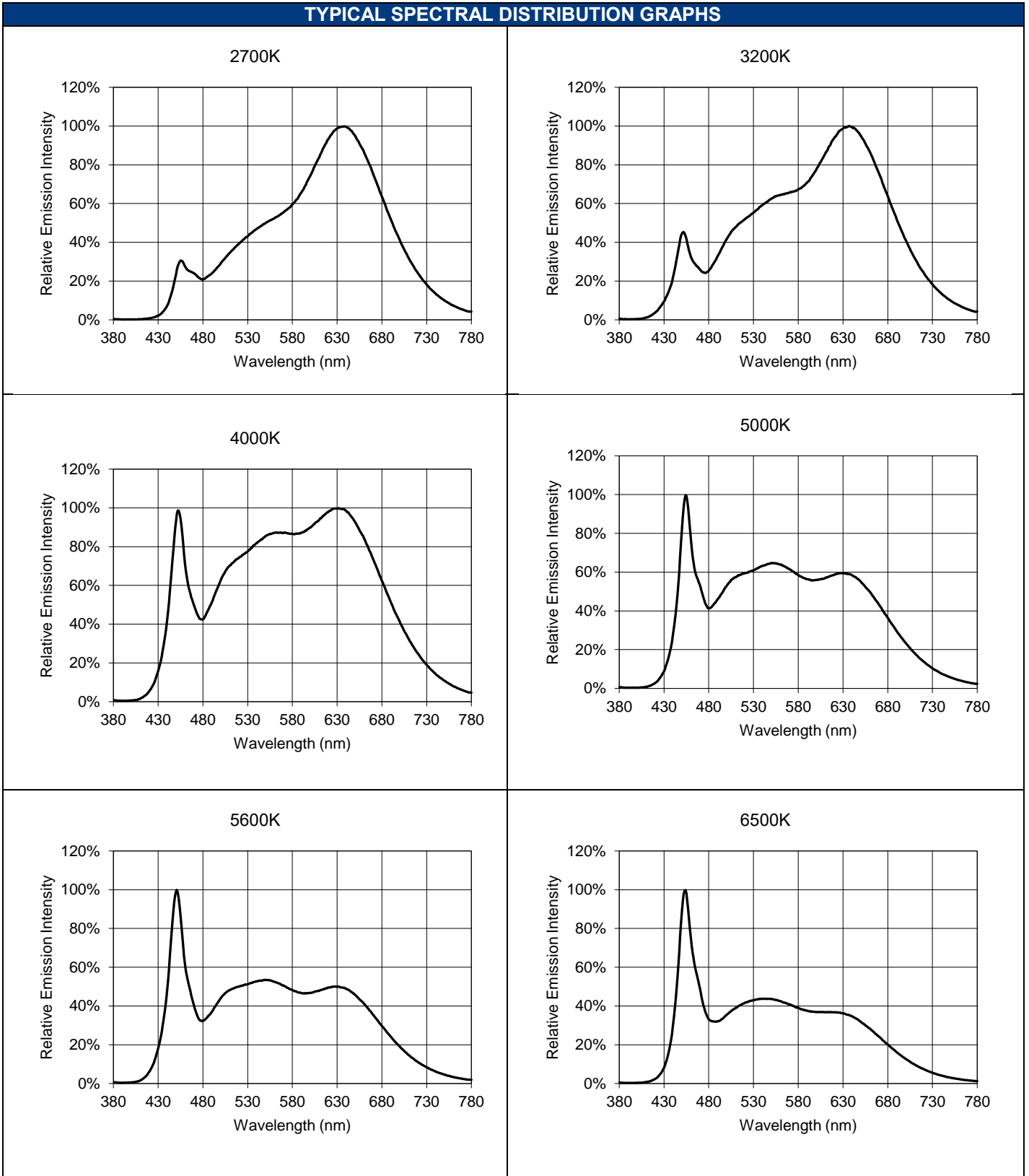

**REFLOW PROFILE**

**SOLDERING RAMP-UP TIME (Pb-FREE)**

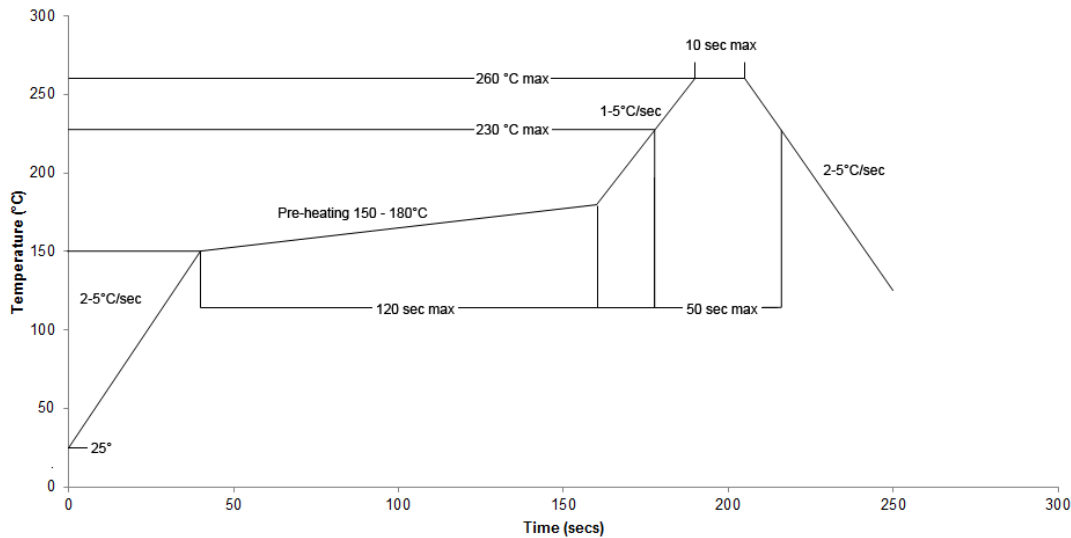

NOTE: Soldering paste with the melting point at 230°C is recommended.

**INSTRUCTIONS FOR SMT**

**Problems caused by improper selection of collet**

Choosing the right collet is important in ensuring product quality after SMT. LEDs are different from other electronic components, as they are not only concerned with electrical output but also optical output. This characteristic makes LEDs more fragile in the process of SMT. If the collet's lowering height is not well set, it will bring damage to the gold wire at the time of collet's pick-and-place process which can cause the LED to not illuminate, flicker or contribute to other quality problems, some of which may not be immediately detectable.

**Collet selection**

During SMT, please choose the collet that has larger outer diameter than the lighting area of lens, in order to avoid damage the gold wire inside the LED. Different collets fit for different products, please refer to the following figures below.



Setting the height of the collet is crucial in order to avoid damage to the top view SMD. If the collet setting is set to too low of an altitude, the collet will press down on the SMD, causing damage or breakage to the encapsulant and cause distortion or breakage of the gold wire.

**Other notes of caution:**

- No pressure should be exerted to the epoxy shell of the SMD under high temperature.
- Do not scratch or wipe the lens since the lens and gold wire inside are rather fragile and cross out easy to break.
- LED should be used as soon as possible when being taken out of the original package, and should be stored in anti-moisture and anti-ESD package.
- This usage and handling instructions are for reference only.



**TAPE SPECIFICATIONS**

TAPE DIMENSIONS (UNIT: MM)

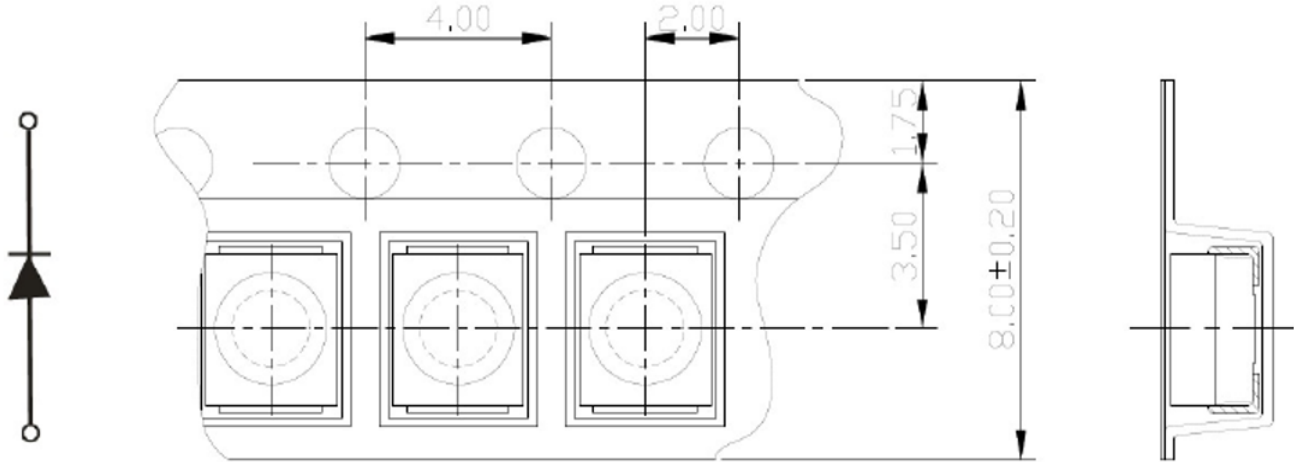

All dimensions in mm, tolerance unless mentioned is  $\pm 0.1$  mm.

TAPE LAYOUT (NOT DRAWN TO SCALE)

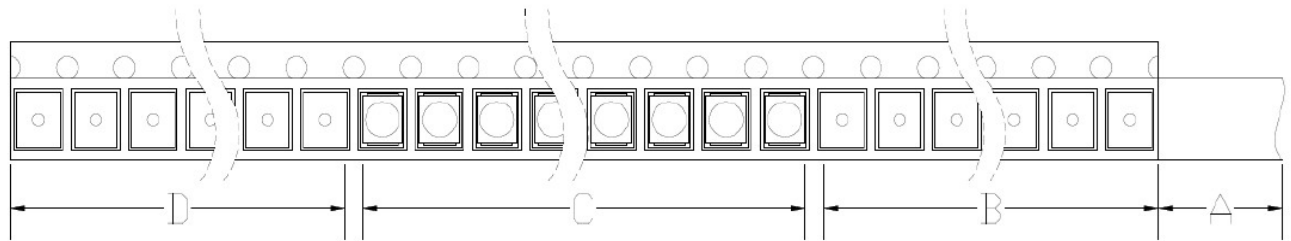

- A: COVER TAPE, 300 MM;
- B: EMPTY LEADER, 200 MM;
- C: LED, 5000 PCS;
- D: EMPTY TRAILER, 200 MM;

**REEL SPECIFICATIONS**

REEL DIMENSIONS TOP (UNIT: MM)

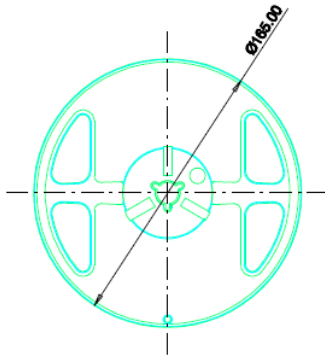

REEL DIMENSIONS BOTTOM (UNIT: MM)

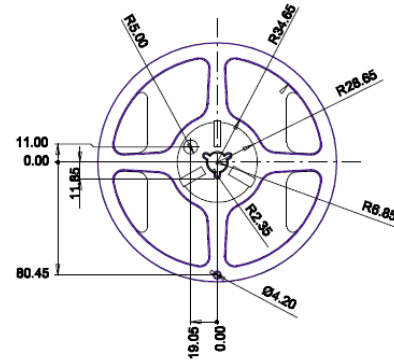

REEL DIMENSIONS SIDE (UNIT: MM)

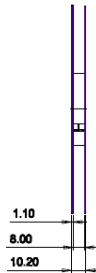

FEEDING DIRECTION

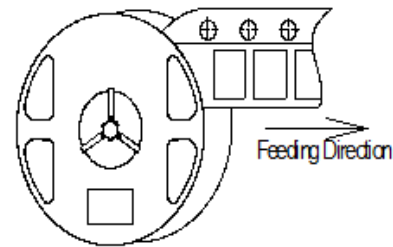

**LOT NUMBERING SCHEME**

Yuji LED uses two formats for lot numbering purposes:

1) YYYY-MM-XXX-Z

YYYY: 4-digit manufacturing year  
MM: 2-digit manufacturing month  
XXX: 3-digit inventory number (000 – 999)  
Z: internal alphanumeric code

2) YYYYMMXXX

YYYY: 4-digit manufacturing year  
MM: 2-digit manufacturing month  
XXX: 3-digit inventory number (000 – 999)

**SHIPPING INFORMATION**

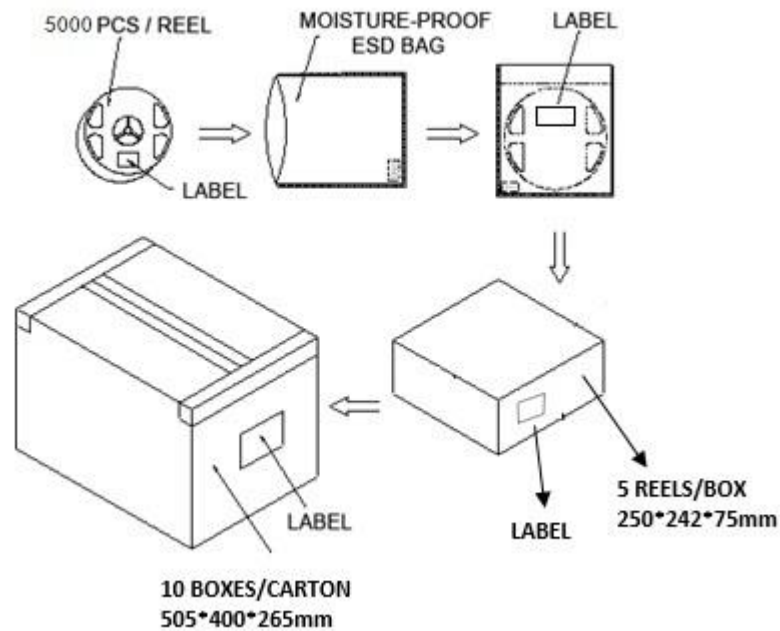

**NOTES:**

1. Reeled products (max 5,000 pcs / reel) are packed in a moisture-proof bag along with a moisture desiccant pack.
2. Each inner box contains up to 5 moisture-proof bag (total maximum number of SMDs is 25,000pcs). Box package size: 246 mm x 225 mm x 76 mm.
3. Each outer package contains 10 inner boxes. Box size: 490 mm x 400 mm x 262 mm.
4. Outer package is sealed with protective bubble wrap and foam. (Part numbers, lot numbers, quantity should appear on the label on the moisture-proof bag, part numbers).
5. This packaging merely intended as a reference for standard quantity orders only – please note that actual packaging can differ depending on the order circumstances.