



YJ-AP-3030-G02

Surface Mount Device



Applications

- High-end architectural lighting
- Photographic/broadcast lighting
- Horticulture lighting
- Human-centric lighting
- Photoelectric device and relevant research

Features

- Industrial high CRI
- Ultra homogeneous spectrum
- Optimized efficacy for full-spectrum
- 3.0mm × 3.0mm universal package
- TM-30 & TLCI specified
- SimpleBinning solution

[About Yujileds[®]](#)

Rev Version: 2.0

P3200007.00

Table of Contents

General description	3
Ordering information	7
Characteristics	8
Chromaticity group and diagram	10
Package material and dimension.....	11
Characteristic graph	12
Solder and reflow profile	17
SMT instruction	18
Tape and reel specifications	19
Box packaging	20
About Yujileds	21

General description

Improving the artificial lighting as close to the sunlight is the eternal pursuit for the top LED manufacturers. However, the artificial lighting gets far away from the naturalness after the incandescent and halogen because the illumination principles of the later artificial lights are far away from the blackbody radiation, including LED.

The sun essentially provides complete and homogenous spectral radiation in the visual wavelengths, while an LED is always combined by the blue or purple semiconductor die with blue/green/amber/red phosphors, in consequence, it is visualized to observe that from an LED spectrum, peaks and gaps always exist because of the respective characteristics of the die and phosphors, which can not be avoided generally.

98% similarity to the CIE A, D50 and D65 illuminant

Yujileds® AP series 3030 LED is based on innovative and revolutionary technologies. It provides an unprecedented spectrum with ultra-homogeneous features within one compact package, where the color rendition performs superbly and stably. The AP series LED comes with three standard spectra of 2700K, 5000K and 6500K corresponding to the CIE illuminants of A, D50 and D65 respectively. Compared to these standards, the AP spectra achieve 98% similarity within one compact package, unprecedented for all of the market's LEDs.

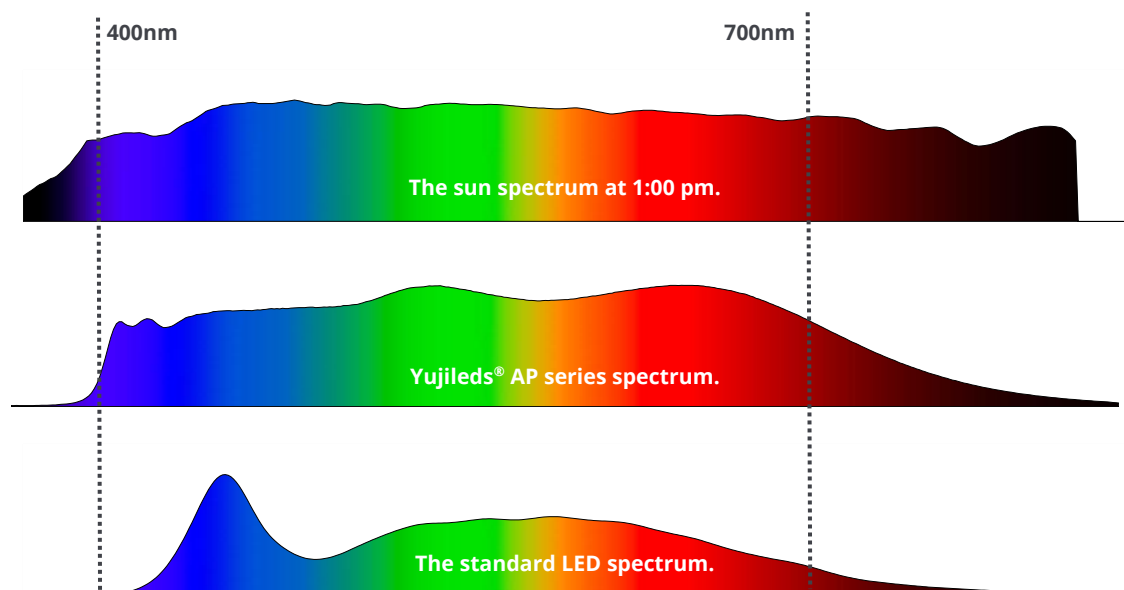

Refuse any peaks or gaps

Standard illuminants always present completely uniform spectral power distributions, where a recent artificial light source can never simulate to a promising degree, especially for LED considering its particular illuminating principle. With the latest technology of Yujileds phosphor and package, it is finally available to achieve the homogeneous spectra, in AP series LED spectra, there is no longer strong peaks or obvious gaps like a regular LED.

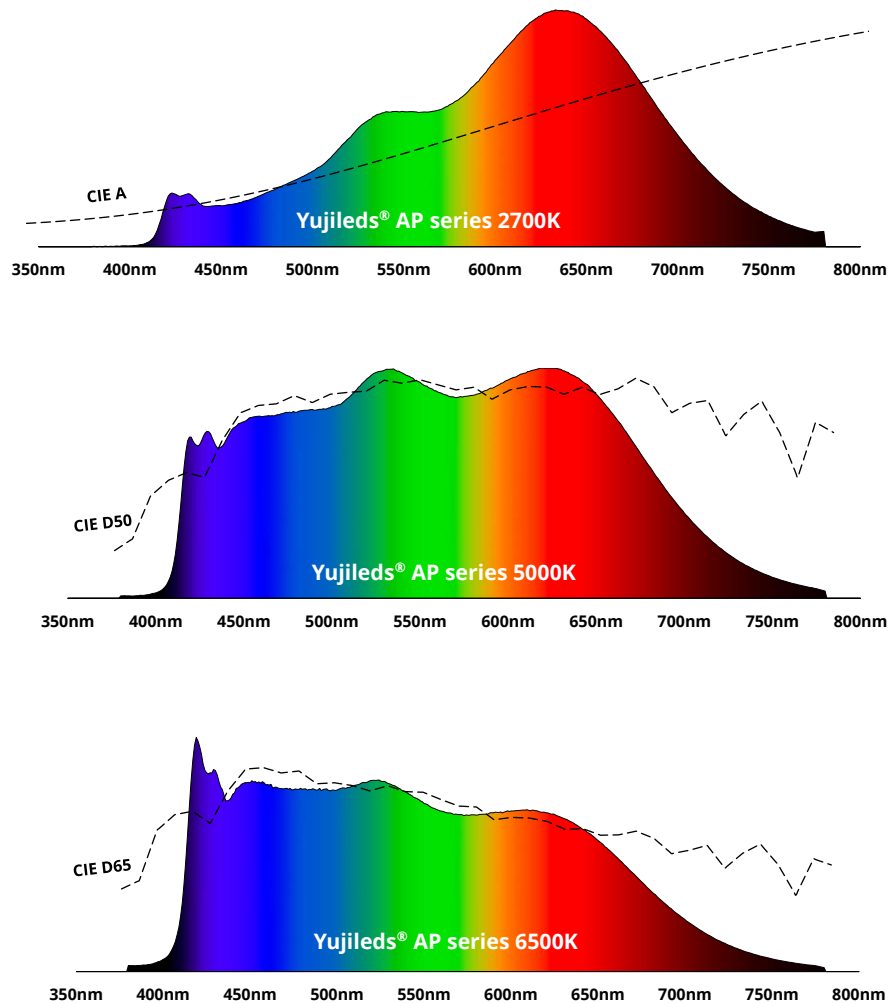

Top-level TM-30 score

The TM-30 is a comprehensive and most convincing method for color rendition. It provides more metrics as the reference, including color fidelity and gamut from 99 evaluation samples, which means, compared to conventional metrics, the TM-30 will disclose more details to present the most authentic performance on color rendition.

The AP series TM-30 measurements are the most intuitive testifications. Giving the Rf 98, Rg 101 and all 99 color fidelities above 95, Yujileds AP series technology wins the highest level on the color rendition, not only for individual metrics but is stable quality.

	Daylight	Yujileds® AP LED	Standard high CRI LED	Standard LED
Fidelity index (Rf)	100	98	90	82
Gamut index (Rg)	100	101	97	95
Fidelity of 99 CES	All = 100	All > 95	Average 90	Average 82
Color Vector Graphic (CVG)				
Color Sample Fidelity				

Up to 99 CRI

Undoubtedly, the AP series performance under CRI metric system is equally top level. Achieving R1-R15 all above 90, the CRI score is up to 99 and is stable on different color temperatures of 2700K, 5000K and 6500K.

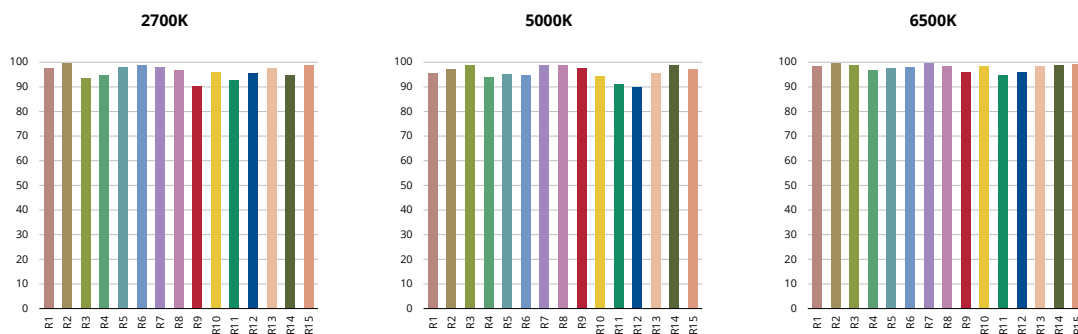

Up to 99 TLCI

Halogen and daylight are the most frequently used color temperatures in the broadcasting lighting environments, with the superb homogeneous spectrum and measure by the TLCI metric, the AP 2700K and 6500K are not compromised in the quality to ensure the correct colors in the cameras.

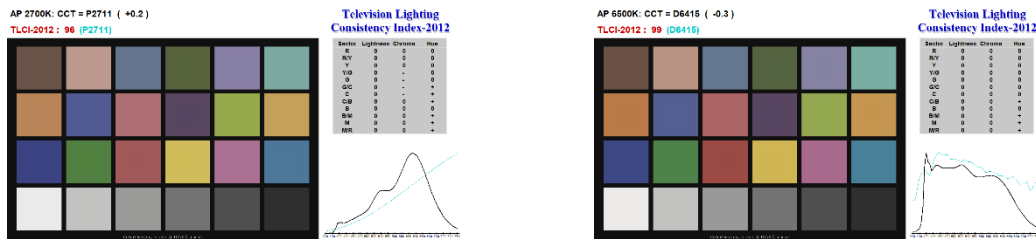

The AP series 3030 LED also supports the unique service/certification by Yujileads® as described below.



TM-30
Specified

TM-30-18 specification

The most advanced colorimetric for color rendition, widely recognized as the successor of CRI.



TLCI
Specified

TLCI specification

Based on the Macbeth ColorChecker, for evaluating the colorimetric quality of the broadcast lighting.

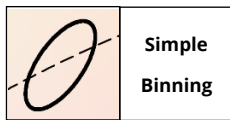

Simple Binning

SimpleBinning specification

Simplify the chromaticity binning with TrueChroma data support to provide the most economical, simple, and practical solution to customers.



RoHS
Compliance

RoHS 2011/65/EU compliance

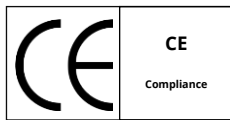

CE
Compliance

CE compliance



REACH
Compliance

REACH compliance (Phosphor)

Ordering information

PART NUMBER	PRODUCT CODE	CCT	CHROMATICITY BINS	VOLTAGE RANGE
YJ-AP-3030-G02-27	P3200007.27	2700K	A27L / A27R	0.1V
YJ-AP-3030-G02-50	P3200007.50	5000K	A50L / A50R	0.1V
YJ-AP-3030-G02-65	P3200007.65	6500K	A65L / A65R	0.1V

Characteristics

Electrical-optical characteristics ($T_A = 25^\circ\text{C}$, 65mA)

PARAMETER	SYMBOL	VALUE			UNIT	TOLERANCE
		MIN.	TYP.	MAX.		
Forward voltage	V_F	2.8	-	3.2	V	± 0.05
Luminous flux	Φ_{2700K}	21	-	23	lm	-
	Φ_{5000K}	23	-	26		
	Φ_{6500K}	23	-	26		
Correlated color temperature⁽¹⁾	CCT_{2700K}	-	2700	-	K	-
	CCT_{5000K}	-	5000	-		
	CCT_{6500K}	-	6500	-		
Color rendering index	R_a	95	-	-	-	± 1
	$R_i (i = 1-15)$	90	-	-	-	-
Fidelity index⁽²⁾	R_f	-	98	-	-	-
Gamut index⁽²⁾	R_g	-	101	-	-	-
TLCI 2012⁽³⁾	-	-	98	-	-	-
Reverse current	I_r	-	-	10	μA	$\pm 0.1 (V_r = 5V)$
View angle	$2\theta_{1/2}$	-	120	-	Deg	± 5

(1). Yujileds® promises the chromaticity coordinate tolerance of ± 0.0015 (CIE 1931 x,y) based on Yuji standard equipment shall prevail.

(2). Defined by the IES TM-30-18 method, this data is for trial.

(3). Defined by the EBU, TLCI is the abbreviation of Television Lighting Consistency Index, this data is for trial.

Characteristics

Absolute maximum ratings ($T_A = 25^\circ\text{C}$)

PARAMETER	SYMBOL	LIMIT	UNIT
Power Consumption	P_D	300	mW
DC Forward Current (pulsed)⁽¹⁾	I_{FP}	130 ⁽²⁾	mA
DC Forward Current	I_F	100	mA
Reverse Voltage	V_R	5	V
Junction Temperature	T_j	120	$^\circ\text{C}$
Solder Point Temperature⁽³⁾	T_s	100	$^\circ\text{C}$
Operating Temperature	T_{opr}	-40 ~ +85	$^\circ\text{C}$
Storage Temperature	T_{stg}	-30 ~ +100	$^\circ\text{C}$
Soldering Temperature	T_{sol}	260 \pm 5 (<10s)	$^\circ\text{C}$
Reflow Cycles Allowed	-	2	-

(1). Pulse width $\leq 0.1\text{ms}$, duty $\leq 1/10$.

(2). Theoretical data.

(3). See page [Package material and dimension](#).

Chromaticity group and diagram

Chromaticity bins & coordinates

CCT	BIN	CIE 1931 COORDINATES							
		X0	Y0	X1	Y1	X2	Y2	X3	Y3
2700K	A27L	0.4506	0.4156	0.4421	0.3996	0.4533	0.4021	0.4623	0.4181
	A27R	0.4623	0.4181	0.4533	0.4021	0.4653	0.4044	0.4756	0.4211
5000K	A50L	0.3345	0.3550	0.3355	0.3410	0.3441	0.3476	0.3453	0.3630
	A50R	0.3453	0.3630	0.3441	0.3476	0.3535	0.3548	0.3556	0.3701
6500K	A65L	0.3000	0.3250	0.3040	0.3140	0.3139	0.3230	0.3110	0.3340
	A65R	0.3110	0.3340	0.3139	0.3230	0.3235	0.3325	0.3218	0.3435

CIE 1931 diagram

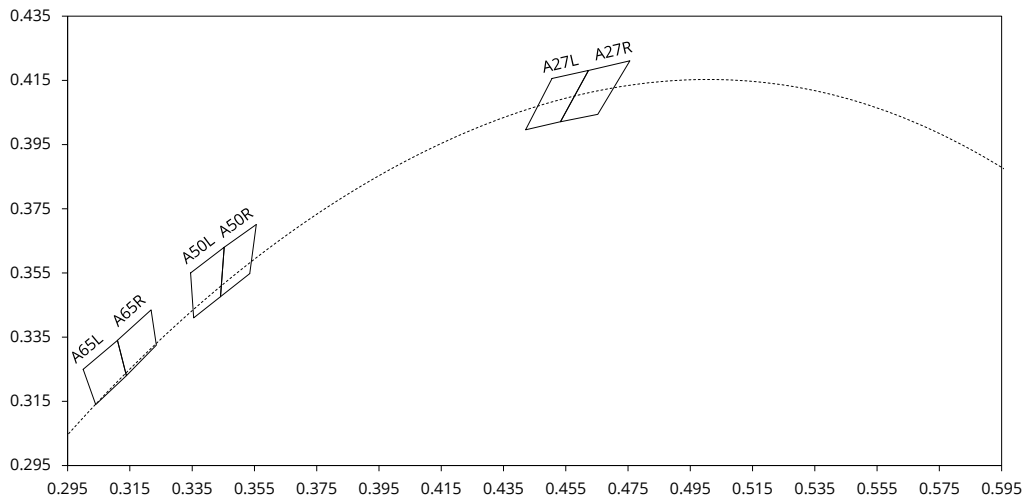

Package material and dimension

Package layout

All dimensions in mm, tolerance unless mentioned is ± 0.1 mm.

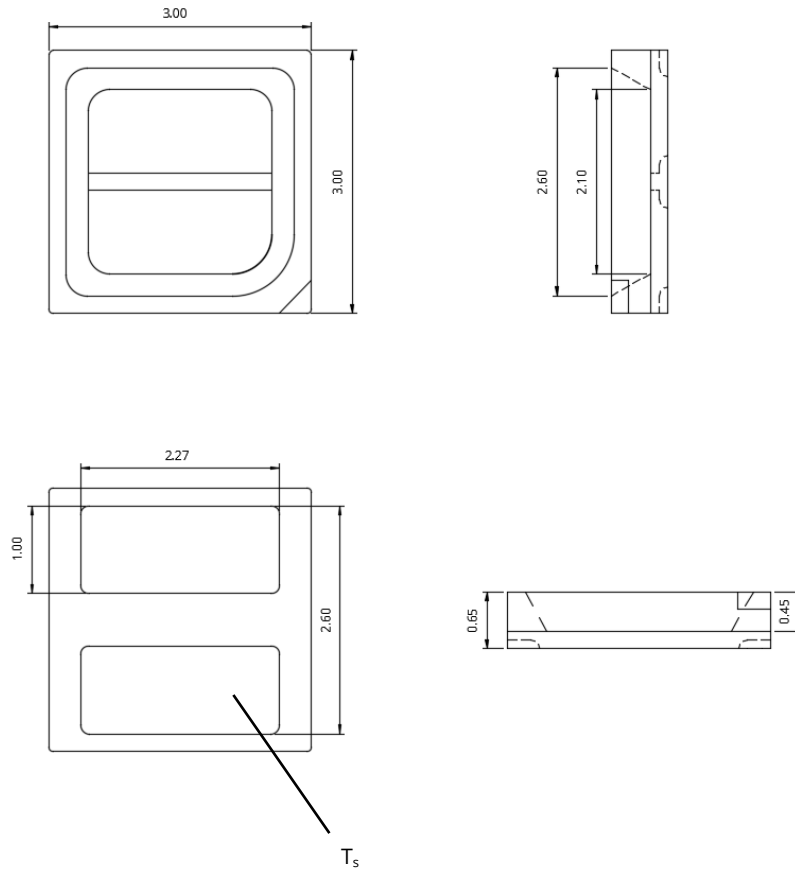

Package materials

ITEM	DESCRIPTION
Die material	InGaN
Lead frame material	EMC
Encapsulant resin material	Silicon + Phosphor
Electrodes material	Silver-plated copper

Characteristic graph

Typical spectral power distribution (normalized)

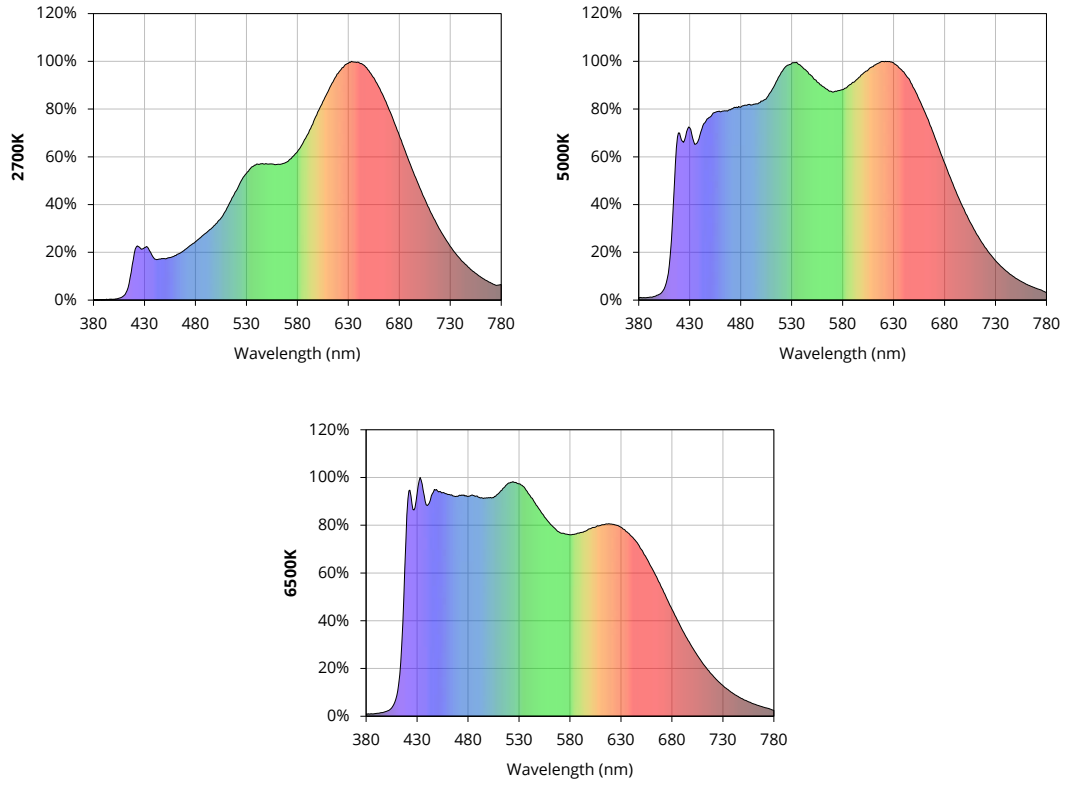

Characteristic graph

Forward current

All characteristic curves are for reference only and not guaranteed.

Vs. forward voltage

($T_A = 25^\circ\text{C}$)

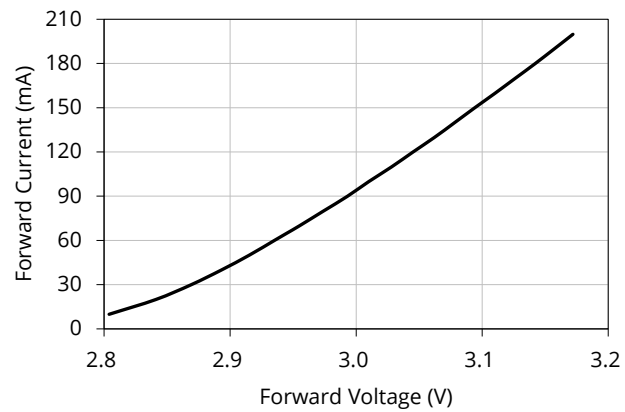

Vs. relative luminous flux

($T_A = 25^\circ\text{C}$)

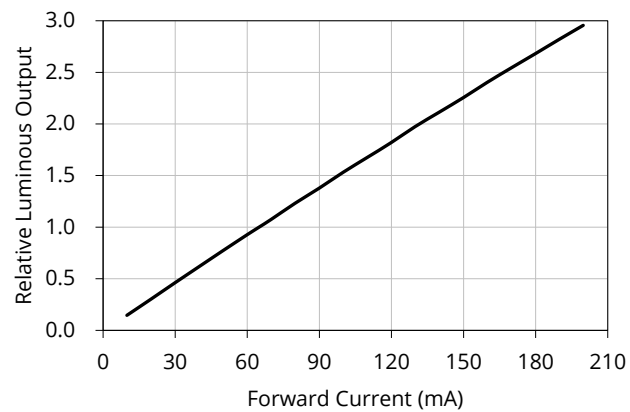

Characteristic graph

Forward current (continued)

All characteristic curves are for reference only and not guaranteed.

Vs. relative chromaticity shift

(5000K, $T_A = 25^\circ\text{C}$)

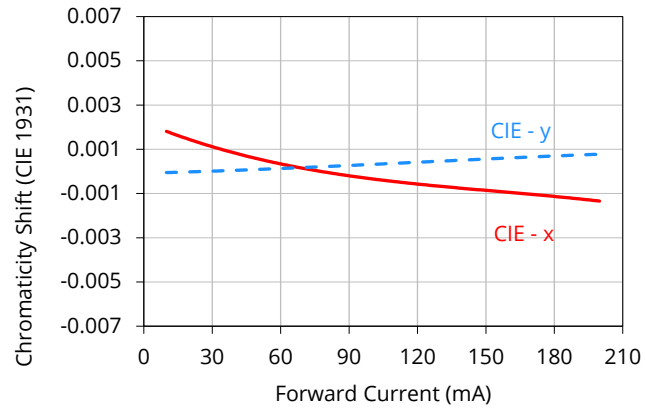

Vs. absolute chromaticity shift

(5000K, $T_A = 25^\circ\text{C}$)

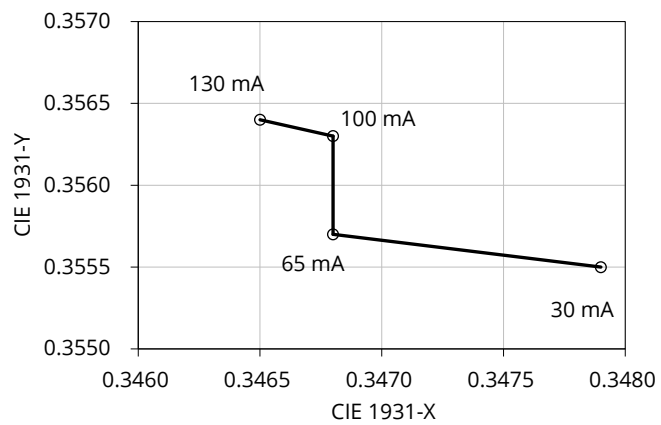

Derating based on solder point

Note: De-rating curves are meant for recommendation only and are not meant to provide guarantees of product stability and longevity.

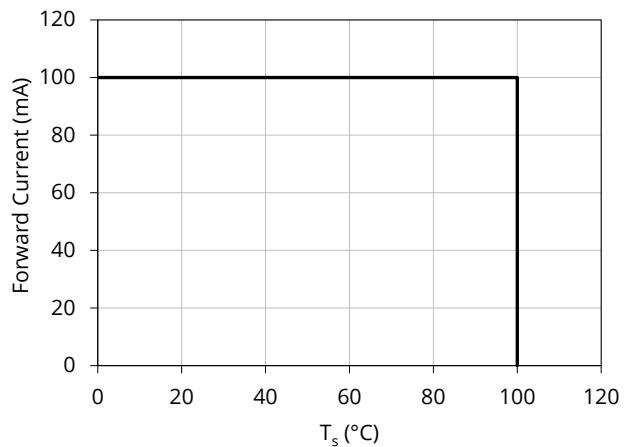

Characteristic graph

Solder point temperature (T_s)

All characteristic curves are for reference only and not guaranteed.

Vs. forward voltage

($I_F = 65\text{mA}$)

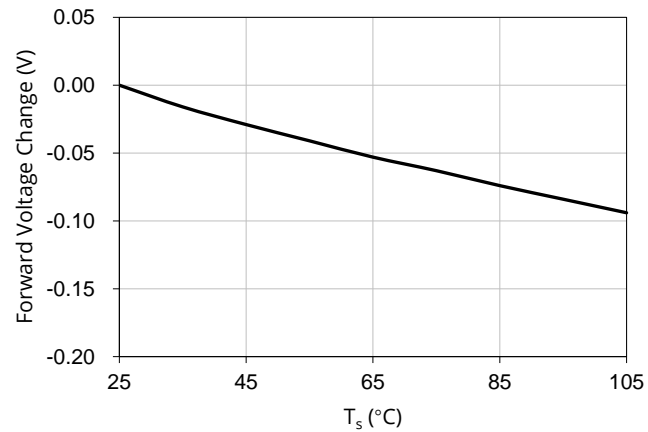

Vs. relative luminous flux

($I_F = 65\text{mA}$)

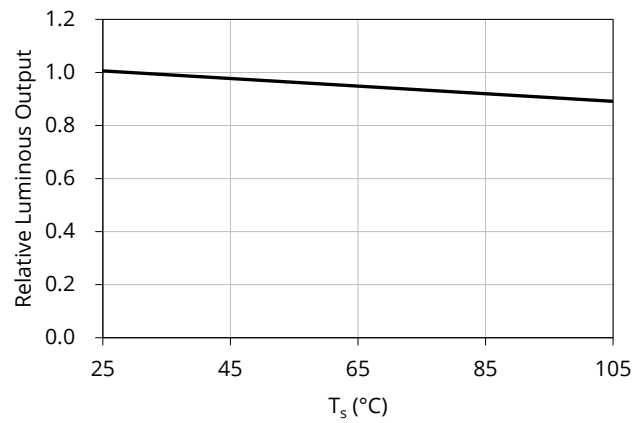

Vs. relative chromaticity shift

(5000K, $I_F = 65\text{mA}$)

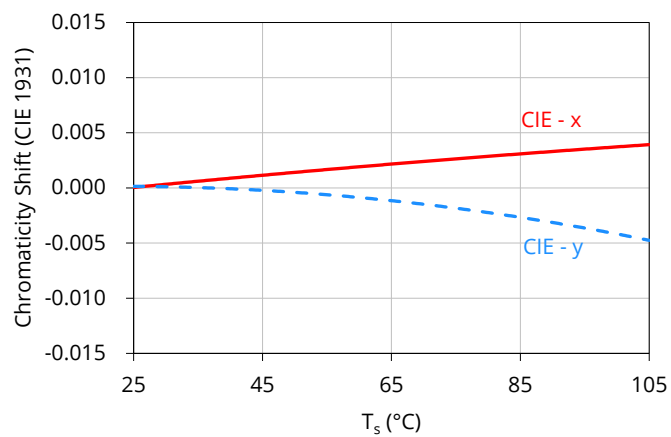

Vs. absolute chromaticity shift

(5000K, $I_F = 65\text{mA}$)

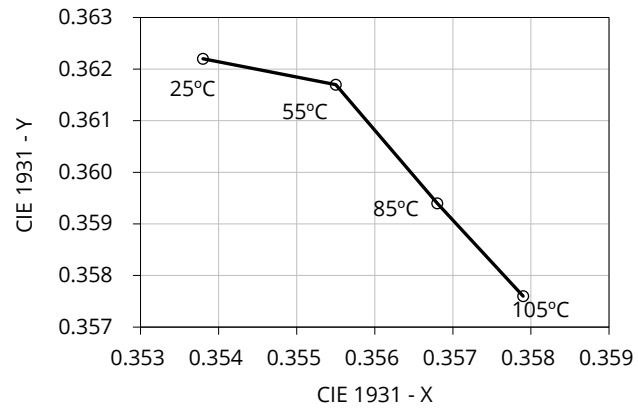

Characteristic graph

Spatial distribution ($T_A = 25^\circ\text{C}$, $I_F = 65\text{mA}$)

All characteristic curves are for reference only and not guaranteed.

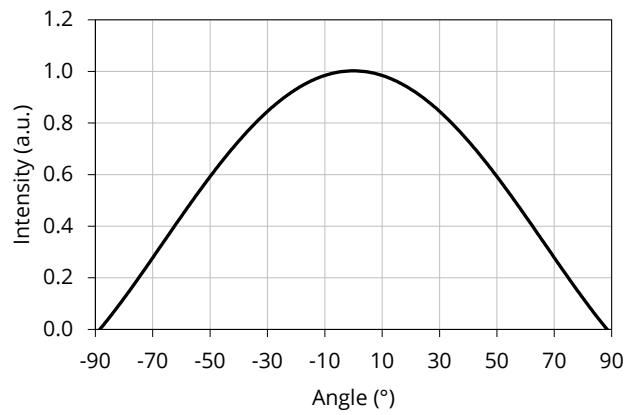

Solder and reflow profile

Recommended solder pad layout

All dimensions in mm, tolerance unless mentioned is ± 0.1 mm.

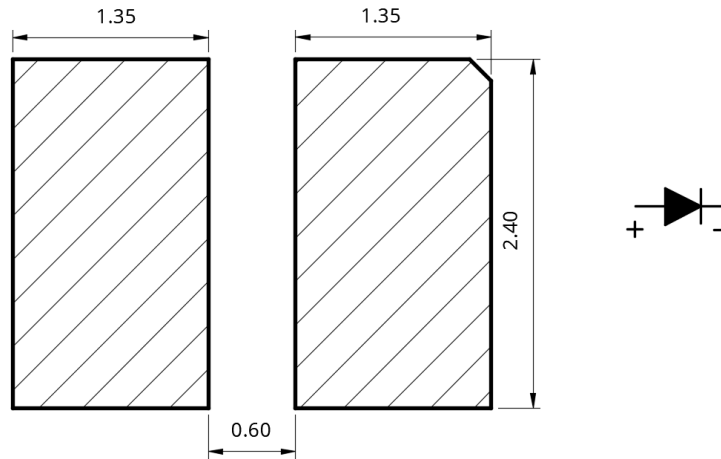

Reflow profile

Soldering ramp-up time (Pb-FREE).

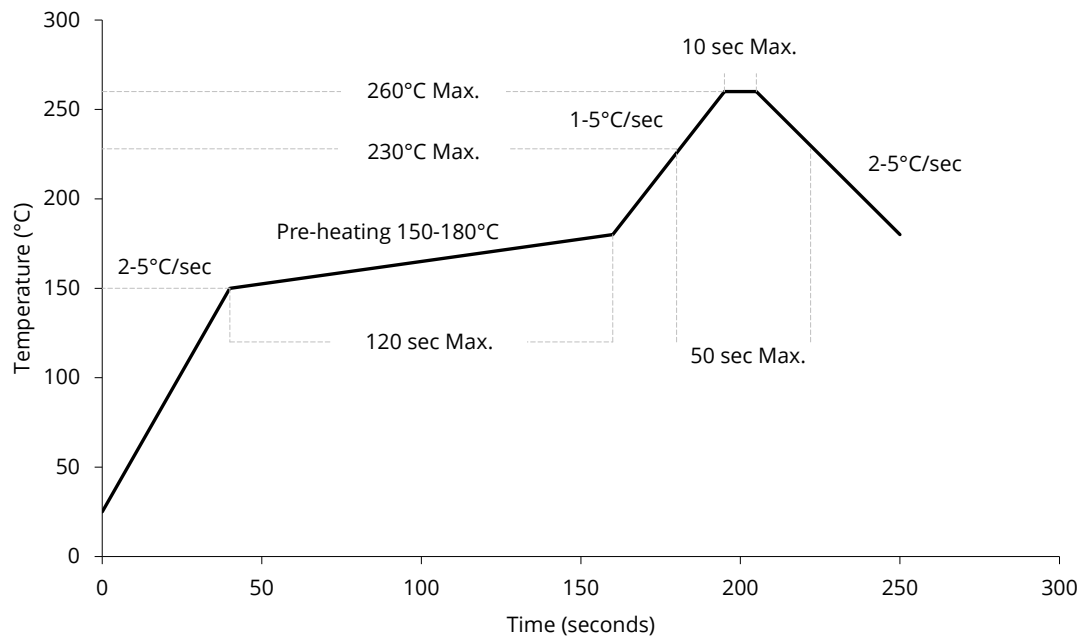

Note: Soldering paste with the melting point at 230°C is recommended.

SMT instruction

Problems caused by improper selection of collet

Choosing the right collet is important in ensuring product quality after SMT. LEDs are different from other electronic components, as they are not only concerned with electrical output but also optical output. This characteristic makes LEDs more fragile in the process of SMT. If the collet's lowering height is not well set, it will bring damage to the gold wire at the time of collet's pick-and-place process which can cause the LED to not illuminate, flicker or contribute to other quality problems, some of which may not be immediately detectable.

Collet selection

During SMT, please choose the appropriate collet in order to avoid damage the gold wire inside the LED or insufficient suction. Setting the height of the collet is crucial in order to avoid damage to the top view SMD. If the collet setting is set to too low of an altitude, the collet will press down on the SMD, causing damage or breakage to the encapsulant and cause distortion or breakage of the gold wire.

Other notes of caution

- No pressure should be exerted to the epoxy shell of the SMD under high temperature.
- Do not scratch or wipe the lens since the lens and gold wire inside are rather fragile and cross out easy to break.
- LED should be used as soon as possible when being taken out of the original package, and should be stored in anti-moisture and anti-ESD package.
- This usage and handling instructions are for reference only.

Tape and reel specifications

Reel dimensions top (unit: mm)

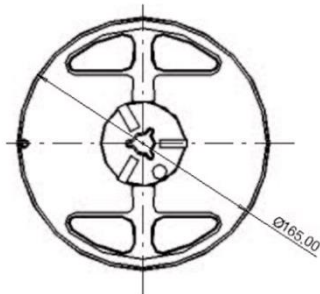

Reel dimensions bottom (unit: mm)

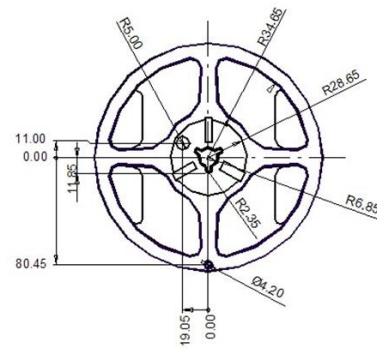

Reel dimensions side (unit: mm)

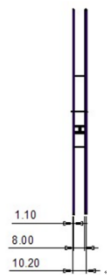

Feeding direction

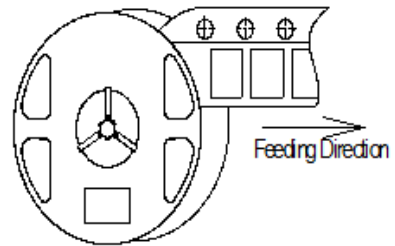

Box packaging

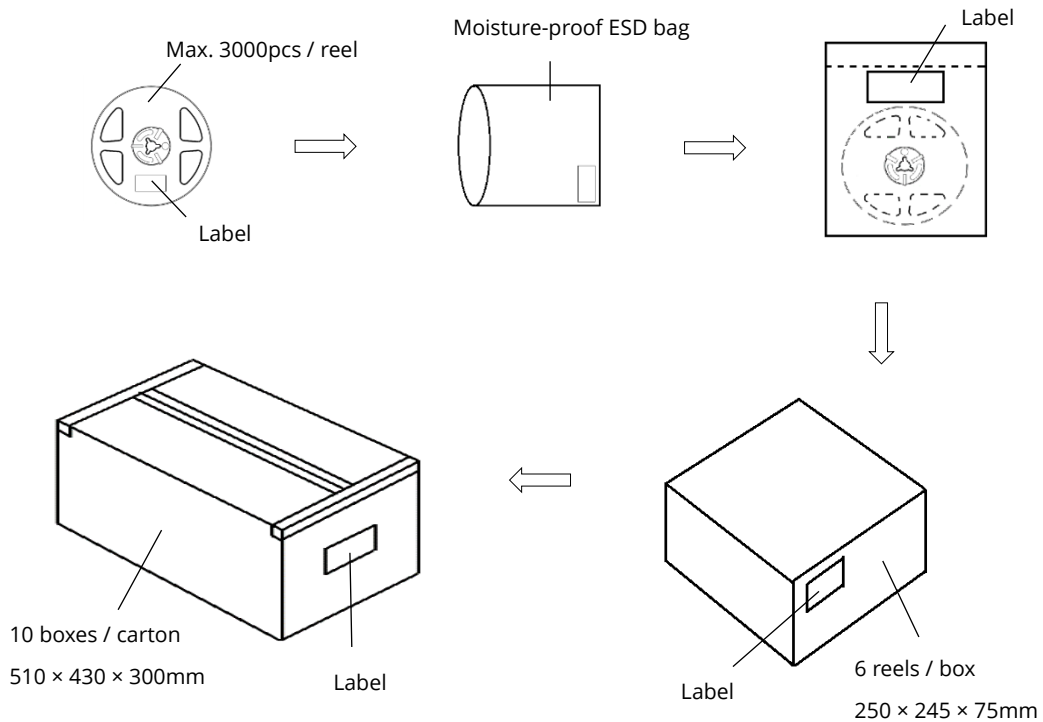

- Reeled products (max 3000pcs / reel) are packed in a moisture-proof bag along with a moisture desiccant pack.
- Each inner box contains up to 6 moisture-proof bag (total maximum number of SMDs is 24000pcs). Box package size: 250 mm × 245 mm × 75 mm.
- Each outer package contains 10 inner boxes. Box size: 510 mm × 430 mm × 300 mm.
- Outer package is sealed with protective bubble wrap and foam. (Part numbers, lot numbers, quantity should appear on the label on the moisture-proof bag, part numbers).
- This packaging merely intended as a reference for standard quantity orders only – please note that actual packaging can differ depending on the order circumstances.

About Yujileads



Our story - Start from the superior stable red LED phosphor.

We started to make LED phosphor materials in 2006. White LEDs were still in very early stage, the industry focused on improving device brightness and efficiency via yellow phosphor very much. No one cared about the light quality. Based on this situation, we took a different approach and focused on red phosphor technology, which is the most important phosphor recipe for high CRI and/or low CCT LEDs, and it made Yuji become a JV partner with Mitsubishi Chemical from 2012.

Today, we are well known for our comprehensive research and full line-up production of LED phosphor from ultra-violet to near-infrared, and we are proud to commit to providing superior stable and efficient phosphors to the worldwide markets.

Our technology - Focus on LED spectrum innovation.

The industrial structure of both phosphor and LED gives us a unique view to develop our spectrum recipes. Compared to the general LED manufacturers, we have comprehensive information in evaluating the feasibility for both technical and commercial aspects. LED spectrum technology is not only about the quality of white LEDs, but also for different applications which have specialized requirements in lighting.

Yuji is one of the few companies that provide the service of designing or customizing a specific spectrum for clients, our confidence comes from the years of accumulation in focusing on the spectrum technologies and the control of LED phosphor and LED die supply-chain with thousands of successful cases in the past years. Innovating LED technologies and giving them commercial values are our eternal driving forces.

Our product - Yujileads®, stands for high-performance LED.

The trademark of Yujileads® is the identification of the LED products developed and manufactured by Yuji. We put our understanding of the LED technologies and the standard of our quality control into every LED we make. Regardless of any product series, we pay attention to expressing the high-performance feature and achieving the product value for clients and never compromise in pursuing the true performance.

Furthermore, we also care about every detail of any documentation we prepare for the product because we

understand the importance to transmit accurate information to clients. It is even more critical for clients to obtain the truth to decide the solution, rather than just a nominal high-performance.

Our client - Outstanding game players in different fields.

Clients are our proudest achievements, now over 200 of our clients are the best game players in their fields in more than 33 countries. We regard the clients' successes as our biggest accomplishments and appreciate their contribution in different fields, clients use our LEDs not just for simple lighting, but to design the lighting for plants, cameras, sensors, health, circadian rhythm, animals, and other industries that we have never imagined that our technologies can be utilized, that makes our work so meaningful.

Our service - Professional supporting team.

There is a group of people in Yuji passionate about creating maximum value for our clients. We have accumulated experience in different projects. Currently, the company gathers more than 30 experts from various fields of semiconductor, chemistry, optics, photoelectricity, circuitry, materials and color science.

Our sales team is well trained in deep LED technologies and has skilled global communication experience. Not just for sales, our team is more like a specialized consultancy to help every client succeed in different projects, and we do not only provide professional business service, but also support in the supply chain, logistics, marketing and technical discussions.

Contact us - We look forward to providing our efficient service for you.

LED website: www.yujiintl.com

Find Yujileds® high-performance LEDs, read our insights into a variety of advanced technologies and applications.

Contact: info@yujigroup.com

LED lighting website: www.yujilighting.com

Find our state-of-art LED lamps and luminaires designed for improving the lighting experience with the vision of illuminating the future.

Contact: lighting@yujigroup.com

Online shop: store.yujiintl.com

Shop your favorite Yuji Lighting product with rapid and professional service.

Contact: webstore@yujigroup.com