



YJ-BC-400L-G01

Chip-on-board LED



Applications

- High-end architectural lighting
- Photographic/broadcast lighting
- Photoelectric device and relevant research

Features

- Industrial high CRI performance
- 50W power consumption
- 46 mm × 40 mm chip-on-board LED
- TLCI & TM-30 specified

[About Yujileds[®]](#)

Rev Version: 2.1

P3150005.00

Table of Contents

General description	2
Ordering information	6
Characteristics	7
Electrical-optical characteristics ($T_A = 25^\circ\text{C}$, 1500mA).....	7
Absolute maximum ratings ($T_A = 25^\circ\text{C}$)	7
Chromaticity group and diagram	8
Chromaticity bins & coordinates	8
CIE 1931 diagram.....	8
Dimension	9
Package layout.....	9
Materials	11
Characteristic graph	12
Typical spectral power distribution (normalized).....	12
Forward current.....	13
Vs. forward voltage.....	13
Vs. relative luminous flux.....	13
Derating based on case temperature	13
Spatial distribution ($T_A = 25^\circ\text{C}$, $I_F = 1500\text{mA}$).....	14
About Yujileds	15

General description

Industrial-leading high CRI technology

Yujileds® BC series LED is based on the efficient blue (typical 450nm) die, mixing with Yuji advanced phosphors and specifically designed spectral recipes. Although there are more and more nominal “high CRI LED” manufacturers on the market, after relevant test and analysis, it is proud to say that Yujileds® BC series LED is still one of the top performance product on the global markets. Achieving typical Ra 97 and minimum Ra 95, the stability and consistent quality in mass production are verified by statistical identification.

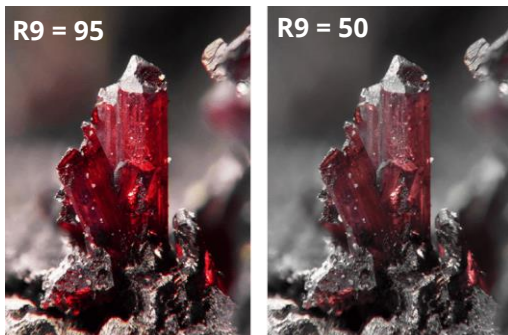
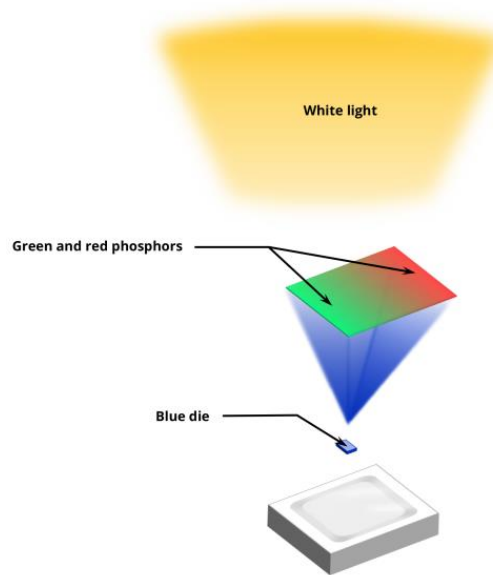

Enhanced CRI R9 technology

The standard CRI Ra is the average score of the first eight Test Color Samples (TCS), where the 9th for saturated red color is missed. However R9 is significantly different for different light sources. In spectral analysis and CRI arithmetic, the integral area between the spectrum and the spectral reflectance response of TCS-9 decides the R9 to a large extent – in other words, how much of TCS-9 spectra reflectance is overlaid in the light source spectrum, that is a key factor.

Light source	R9
Halogen (2865K)	99
Fluorescent (3000K)	-27
Standard LED (3000K)	13
Yujileds® BC series LED (3000K)	96

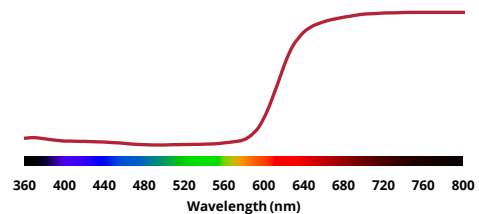

It is obvious to see from 600nm, which is just the start of red color in the visible spectrum, the TCS-9 spectral reflectance raises sharply, in consequence, if the light source does not have sufficient spectral power distribution in 600nm-800nm, it will be difficult to get a high

R9. The capability of rendering the red color cannot be promised if the red spectrum is missed or not sufficient in the original light. In the comparison of fluorescent and halogen, apparently, halogen offers the richest 600+nm power, while the discrete fluorescent spectrum has limited energy there. Then in this comparison, halogen R9 = 99 but the fluorescent is R9 = -27. Comparing a standard LED to Yujileds® BC series LED at 3000K, although the emission principle is the same, the results present different R9 significantly where the standard LED is R9 = 13 and Yujileds® BC series LED is R9 = 96.

Transcend high CRI

High CRI becomes the tendency for LED products in recent years, and manufacturers start providing “nominal” high CRI LED to the market, however, as the result of a detailed investigation, most manufacturers’ high CRI LED are limited in the range of 2700K-5000K, where lower and higher CCTs are missed when applying to more specific applications. Yujileds® BC series LED extends high CRI performance from 1800K to 20000K CCT.

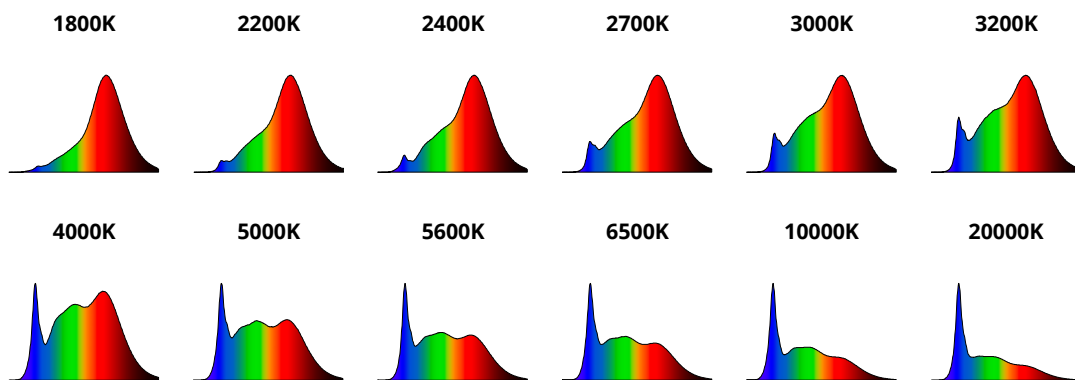

In comparison to a standard LED on the market is generally in the available CCT range of 2700K-6500K, and high CRI LEDs are more limited to fewer options, Yujileds® BC series LED can be extended to 1800K-20000K with the unique phosphor solutions, maintaining the CRI still above 92-97 and excellent spectral qualities. Moreover, looking into the specific Ri in each CCT, the color rendition is well balanced without significant difference, even for the extreme CCTs. Therefore, the CRI is always consistent regardless of what CCT we combine with the BC series LEDs.

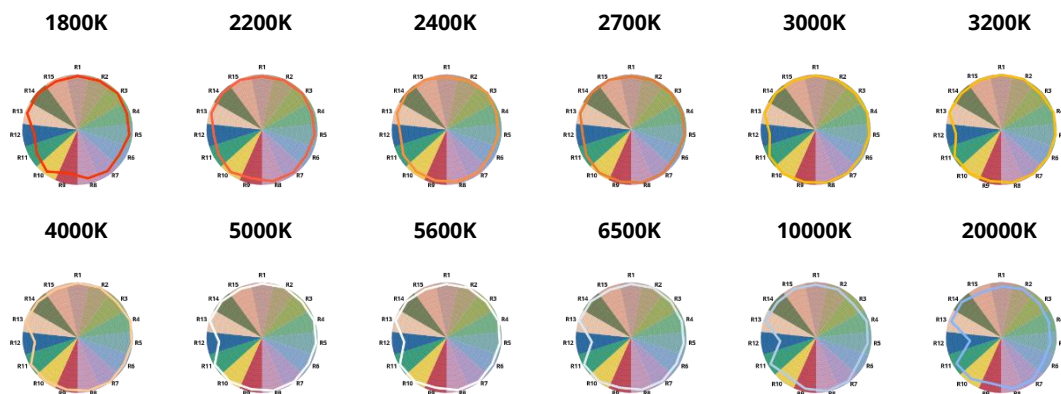

CRI statistic support - introducing the plot box statistics.

In actual applications, LED can work individually or as a group on a printed circuit board, therefore the consistent CRI is critical for both. Generally, a manufacturer only provides a typical datasheet or report to infer the overall performance but the risk is that if some LEDs in a batch have worse CRI but the typical report cannot match, especially when the application uses fewer LEDs which means CRI is difficult to be averaged with those higher ones, then the risk falls to the customers' lighting fixture.

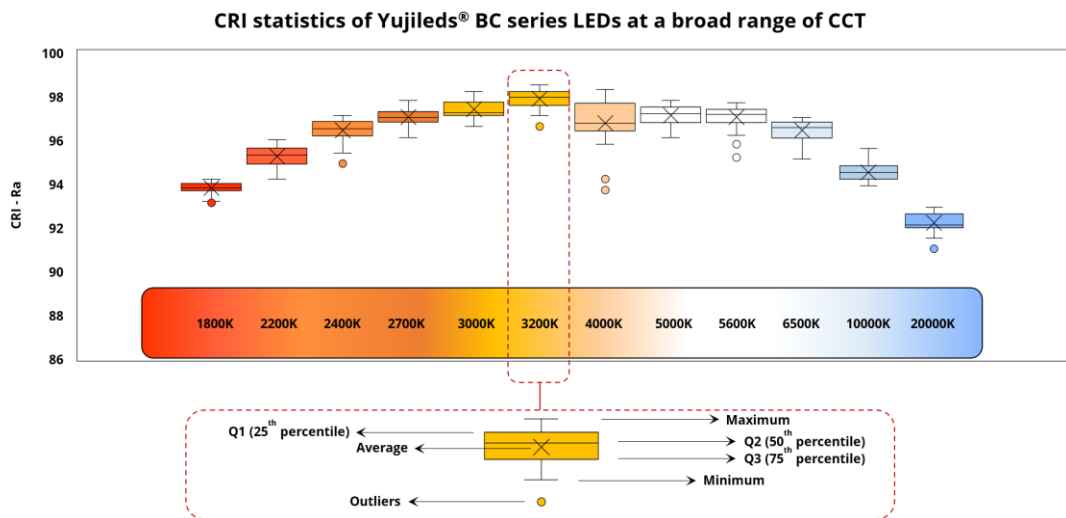

Understanding the statistical features of LED and processing relevant analysis and control are important in this case, and these are what we do for our BC series LED. We provide the full statistic and data support from the production of 1,000,000pcs of each CCT from 1800K to 20000K, and present all characteristics and guidance for customers to make reliable simulation and prediction accordingly. And from the statistical data, we can also read that the BC series LED perform excellently on the CRI consistency.

The BC series 400L LED also supports the unique service/certification by Yujileds® as described below.



TM-30-18 specification

The most advanced colorimetric for color rendition, widely recognized as the successor of CRI.



TLCI specification

Based on the Macbeth ColorChecker, for evaluating the colorimetric quality of the broadcast lighting.

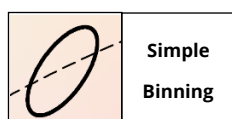

SimpleBinning specification

Simplify the chromaticity binning with TrueChroma data support to provide the most economical, simple, and practical solution to customers.



REACH compliance (Phosphor)

Ordering information

PART NUMBER	PRODUCT CODE	CCT	CHROMATICITY BINS
YJ-BC-400LS-G01-32	P3150005.32	3200K	32L, 32R
YJ-BC-400LS-G01-56	P3150005.56	5600K	56L, 56R
YJ-BC-400LS-G01-XX	P3150005.XX	Custom CCT	-

Characteristics

Electrical-optical characteristics ($T_A = 25^\circ\text{C}$, 1500mA)

PARAMETER	SYMBOL	VALUE			UNIT	TOLERANCE
		MIN.	TYP.	MAX.		
Forward voltage	V_F	28	-	31	V	± 0.05
Luminous flux	$\Phi_{3200\text{K}}$	3025	-	3575	lm	-
	$\Phi_{5600\text{K}}$	3190	-	3740		
Correlated color temperature¹	$\text{CCT}_{3200\text{K}}$	3050	3200	3350	K	-
	$\text{CCT}_{5600\text{K}}$	5300	5600	5900		
Color rendering index	R_a	95	-	-	-	± 1
TCS R9 (CRI red)	R_9	-	90	-	-	-
Fidelity index²	R_f	-	92	-	-	-
Gamut index²	R_g	-	100	-	-	-
TLCI 2012³	-	-	98	-	-	-
Reverse current	I_r	-	-	50	μA	$\pm 0.1 (V_r = 50\text{V})$
View angle	$2\theta_{1/2}$	-	120	-	Deg	± 5

1. Yujileds® promises the chromaticity coordinate tolerance of ± 0.0015 (CIE 1931 x,y) based on Yuji standard equipment shall prevail.
2. Defined by the IES TM-30-18 method, this data is for trial.
3. Defined by the EBU, TLCI is the abbreviation of Television Lighting Consistency Index, this data is for trial.

Absolute maximum ratings ($T_A = 25^\circ\text{C}$)

PARAMETER	SYMBOL	LIMIT	UNIT
Power Consumption	P_D	175	W
DC Forward Current (pulsed)¹	I_{Fp}	10000 ²	mA
DC Forward Current	I_F	5000	mA
Reverse Voltage	V_R	50	V
Junction Temperature	T_j	125	$^\circ\text{C}$
Case Temperature³	T_s	65	$^\circ\text{C}$
Operating Temperature	T_{opr}	-30 ~ +80	$^\circ\text{C}$
Storage Temperature	T_{stg}	-30 ~ +80	$^\circ\text{C}$
Soldering Temperature	T_{sol}	260 \pm 5	$^\circ\text{C}$
Reflow Cycles Allowed	-	2	-

1. Pulse width $\leq 0.1\text{ms}$, duty $\leq 1/10$.
2. Theoretical data.
3. See page [Dimension](#).

Chromaticity group and diagram

Chromaticity bins & coordinates

CCT	BIN	CIE 1931 COORDINATES							
		X0	Y0	X1	Y1	X2	Y2	X3	Y3
3200K	32L	0.4194	0.4042	0.4130	0.3882	0.4201	0.3909	0.4269	0.4069
	32R	0.4269	0.4069	0.4201	0.3909	0.4275	0.3935	0.4347	0.4095
5600K	56L	0.3237	0.3401	0.3243	0.3269	0.3303	0.3320	0.3300	0.3460
	56R	0.3300	0.3460	0.3303	0.3320	0.3370	0.3378	0.3372	0.3526

CIE 1931 diagram

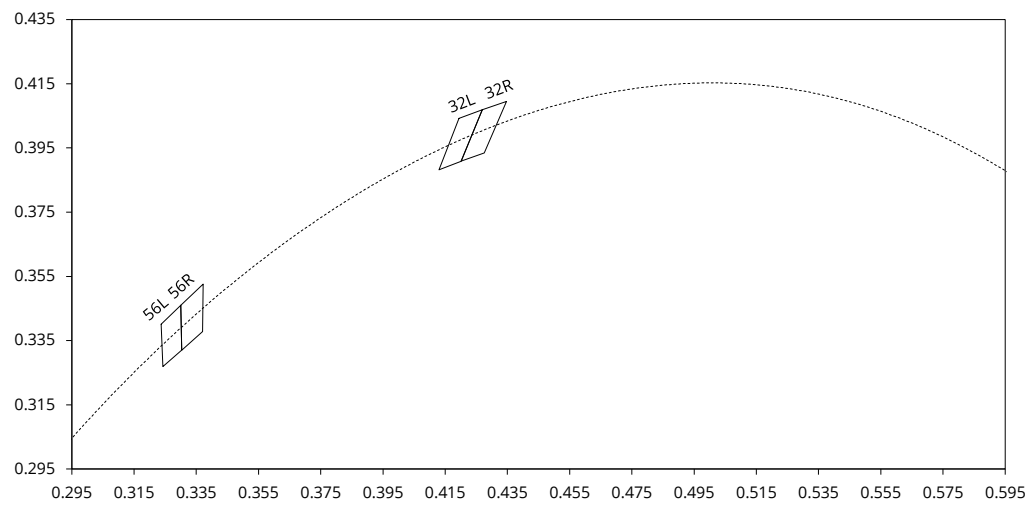

Dimension

Package layout

All dimensions in mm, tolerance unless mentioned is ± 0.1 mm.

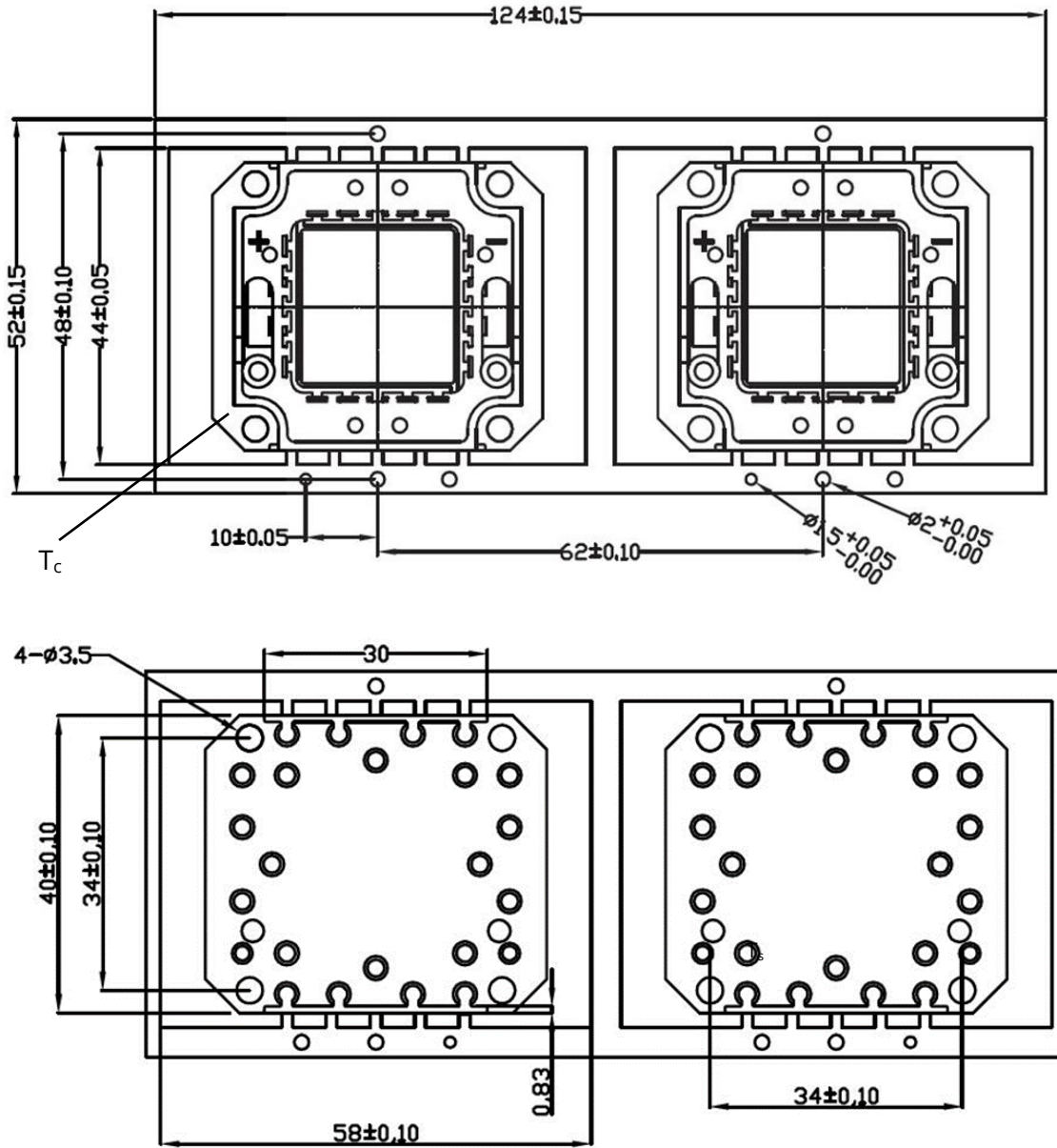

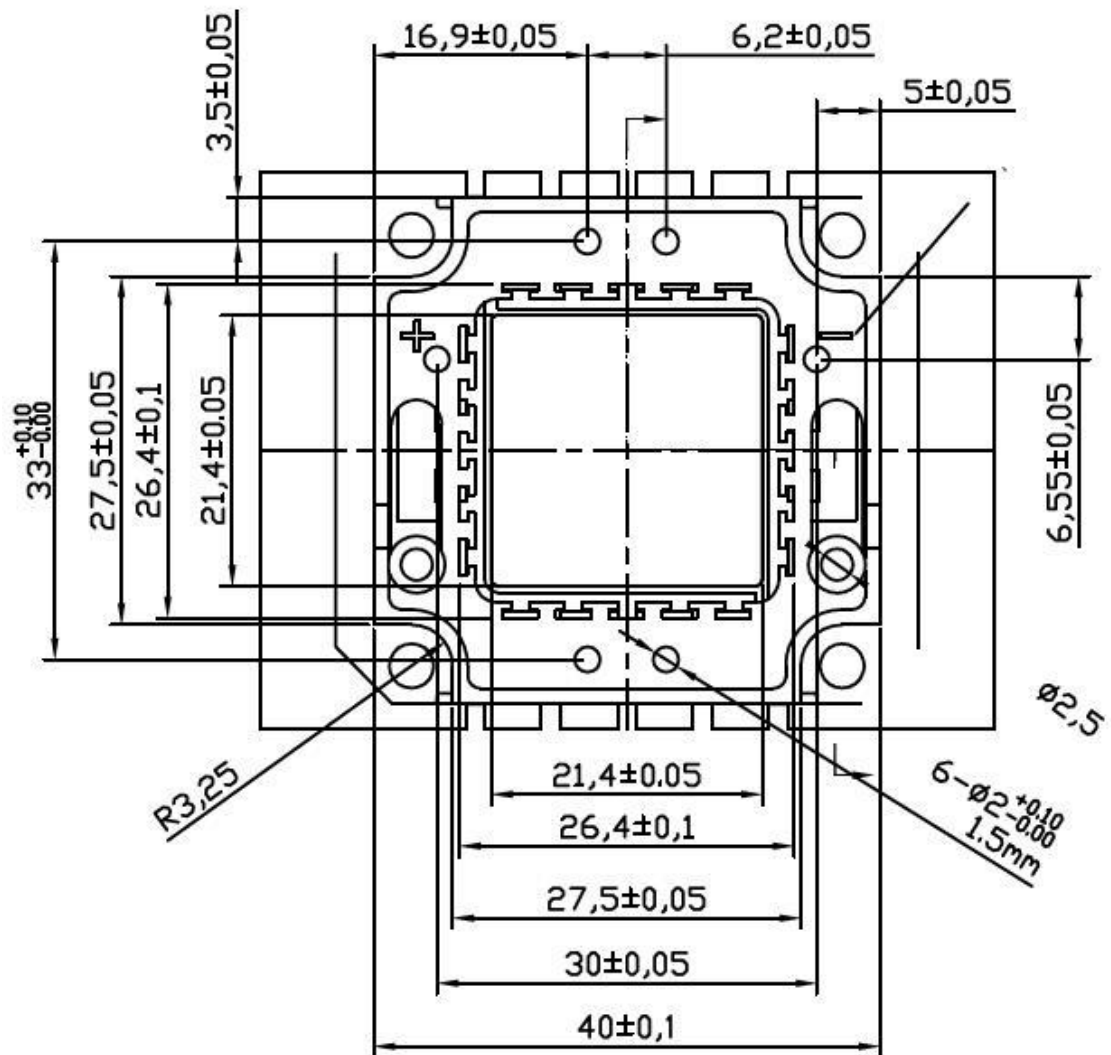

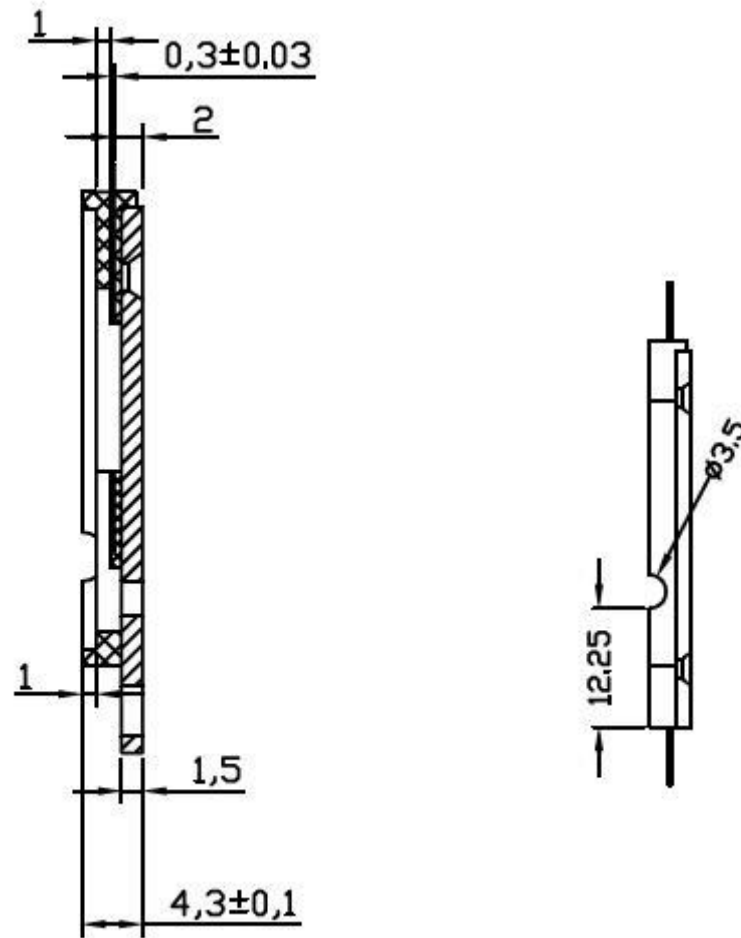

Materials

ITEM	DESCRIPTION
Die material	InGaN
Lead frame material	Copper Alloy
Encapsulant resin material	Silicon + Phosphor
Electrodes material	Cooper+Silver Alloy

Characteristic graph

Typical spectral power distribution (normalized)

All characteristic curves are for reference only and not guaranteed.

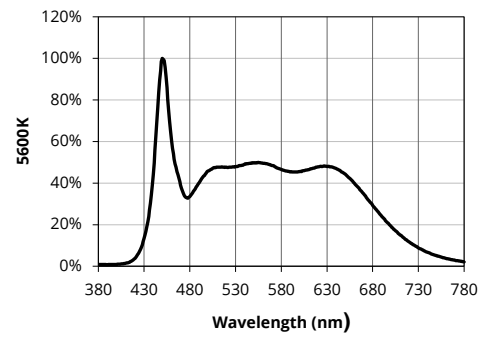
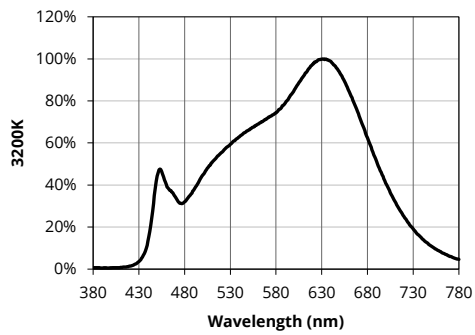

Characteristic graph

Forward current

All characteristic curves are for reference only and not guaranteed.

Vs. forward voltage

($T_A = 25^\circ\text{C}$)

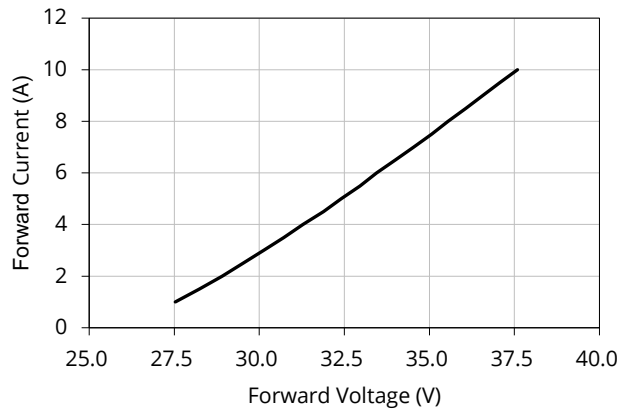

Vs. relative luminous flux

($T_A = 25^\circ\text{C}$)

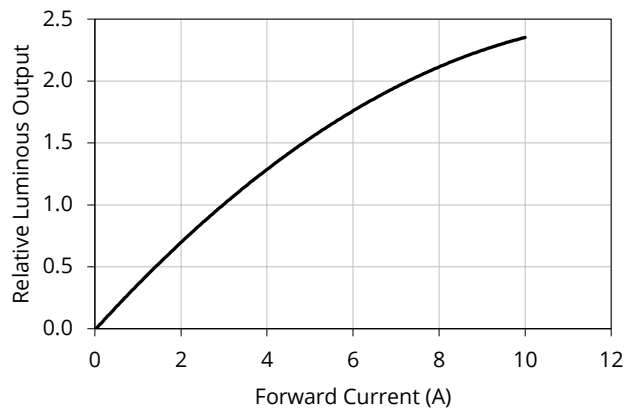

Derating based on case temperature

Note: De-rating curves are meant for recommendation only and are not meant to provide guarantees of product stability and longevity.

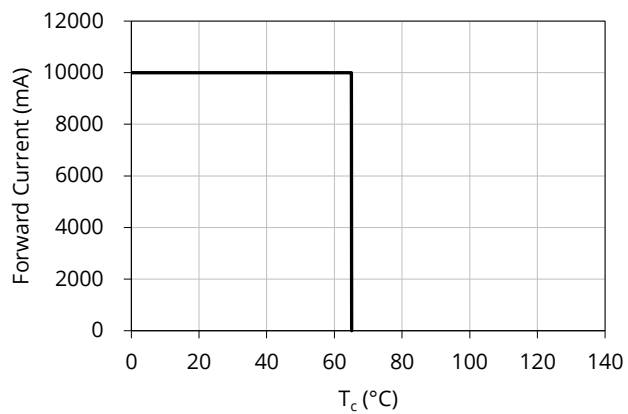

Characteristic graph

Spatial distribution ($T_A = 25^\circ\text{C}$, $I_F = 1500\text{mA}$)

All characteristic curves are for reference only and not guaranteed.

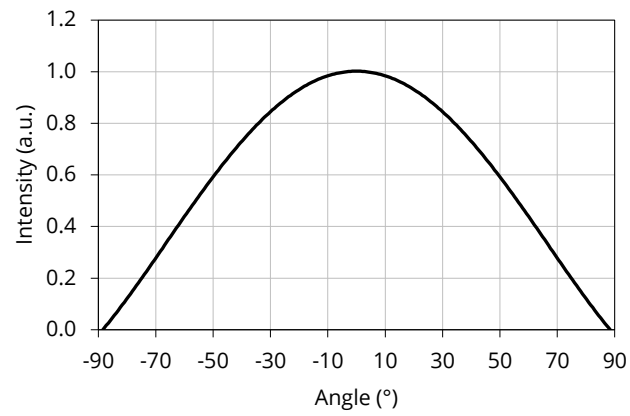

About Yujileds



The Yuji story

Yuji started with LED phosphor materials in 2006, and today we are known for nitride red LED phosphor with superior brightness and stability in the world. With the rapid growth in LED industry during the past years, we have serviced over 260 business customers in over 33 different countries or regions, and established subsidiaries or distributors in 6 locations including China, US, UK and Japan, now we are reaching the global markets with the full coverage efficiently.

Our capabilities and achievements

In Yujileds®, we are a group of people passionate in creating the maximum value for customers. Dedicated to developing LED phosphor, LED light source and final products, we have accumulated unique experience in different projects. Nowadays, over 30 experts are gathered in a variety of areas including but not limited to semiconductor, chemistry, optics, photoelectricity, circuitry, materials and color science.

In commercial markets, we have been dedicating to providing comprehensive solutions for specific applications by deeply understanding these markets. Our goal is not only to offer an LED product simply but is to grow with customers and share the success of a business.

Main website: www.yujiintl.com

Find the comprehensive introduction of Yuji company and our insights into a variety of advanced technologies and applications.

Contact: info@yujigroup.com

Subordinative website: www.yujileds.com

Find more about our products, technical posts, featured support and service, blogs, news and whatever interesting and practical information.

Contact: contact@yujileds.com

Online shop: store.yujiintl.com

Find your favorite Yujileds® products with outstanding quality, fast shipment and superb sale service.

Contact: webstore@yujigroup.com