



YJ-BC-RGBW5050-G02

Surface Mount Device

Applications

- High-end architectural lighting
- Photographic/broadcast lighting
- Photoelectric device and relevant research

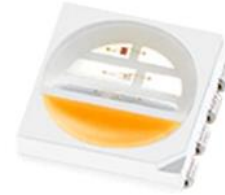

Features

- Industrial highest CRI performance of white light
- Full-color gamut of red, green and blue
- 5.5mm × 5.0mm package
- TLCI & TM-30 specified (white light)
- SimpleBinning solution (white light)

[About Yujileads[®]](#)

Rev Version: 2.1

P3180012.00

Table of Contents

General description	3
Ordering information	4
Characteristics	5
Electrical-optical characteristics.....	5
Absolute maximum ratings	5
Chromaticity group and diagram	6
Chromaticity bins & coordinates	6
CIE 1931 diagram.....	6
Package material and dimension.....	7
Package layout.....	7
Characteristic graph	8
Typical spectral power distribution	8
Spatial distribution	9
Reflow profile	10
SMT instruction	12
Problems caused by improper selection of collet.....	12
Collet selection.....	12
Other notes of caution.....	12
About YujileDS	12

General description

Yujileds® Multichromatic series RGBW5050 LED is an innovative low-power LED. It integrates four different color channels in a compact package. With Yujileds® advanced phosphors technology, the white light channel achieves industrial high CRI performance and consistency, and the color channels reach saturated and stable monochromatic. The compact package and high output make the LED suitable for a wide variety of applications demanding higher color quality and homogeneous lighting distribution, and it also simplifies the optical design.

The Multichromatic series RGBW5050 LED also supports the unique service/certification by Yujileds® as described below.



TM-30-18 specification

The most advanced colorimetric for color rendition, widely recognized as the successor of CRI.

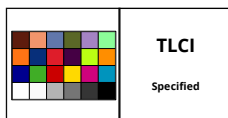

TLCI specification

Based on the Macbeth ColorChecker, for evaluating the colorimetric quality of the broadcast lighting.

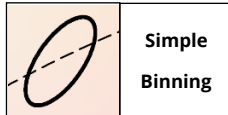

SimpleBinning specification

Simplify the chromaticity binning with TrueChroma data support to provide the most economical, simple, and practical solution to customers.



RoHS 2011/65/EU compliance



REACH compliance (Phosphor)

Ordering information

PART NUMBER	PRODUCT CODE	CCT	CHROMATICITY BINS	VOLTAGE RANGE
YJ-BC-RGBW5050-G02-32	P3180012.32	3200K	32N	0.2V for W 0.4V for R/G/B
YJ-BC-RGBW5050-G02-56	P3180012.56	5600K	56T	0.2V for W 0.4V for R/G/B

Characteristics

Electrical-optical characteristics ($T_A = 25^\circ\text{C}$, 20mA)

COLOR	PARAMETER	SYMBOL	VALUE			UNIT
			MIN.	TYP.	MAX.	
Red	Forward voltage	V_F	1.8	-	2.4	V
	Intensity	Φ	2.0	-	4.0	lm
	Dominant wavelength ⁽¹⁾	λ	615	-	625	nm
	View angle	$2\theta_{1/2}$	-	120	-	Deg
	Reverse current	I_r	-	-	1	μA
Green	Forward voltage	V_F	2.7	-	3.4	V
	Intensity	Φ	5.0	-	7.0	lm
	Dominant wavelength ⁽¹⁾	λ	515	-	525	nm
	View angle	$2\theta_{1/2}$	-	120	-	Deg
	Reverse current	I_r	-	-	1	μA
Blue	Forward voltage	V_F	2.7	-	3.4	V
	Intensity	Φ	1.0	-	3.0	lm
	Dominant wavelength ⁽¹⁾	λ	460	-	470	nm
	View angle	$2\theta_{1/2}$	-	120	-	Deg
	Reverse current	I_r	-	-	1	μA
White	Forward voltage	V_F	2.7	-	3.3	V
	Luminous flux	$\Phi_{3200\text{K}}$	5.0	-	8.0	lm
		$\Phi_{5600\text{K}}$	5.0	-	8.0	
	Correlated color temperature ⁽¹⁾	$\text{CCT}_{3200\text{K}}$	3000	3200	3400	K
		$\text{CCT}_{5600\text{K}}$	5300	5600	5900	
	Color rendering index	Ra	-	95	-	-
	TCS R9 (CRI red)	R9	-	90	-	-
	Fidelity index ⁽²⁾	Rf	-	92	-	-
	Gamut index ⁽²⁾	Rg	-	100	-	-
	TLCI 2012 ⁽³⁾	-	-	97	-	-
View angle	$2\theta_{1/2}$	-	120	-	Deg	
Reverse current	I_r	-	-	1	μA	
Reverse current	I_r	-	-	1	μA	

(1). Yujileds® promises the chromaticity coordinate tolerance of ± 0.0015 (CIE 1931 x,y) based on Yuji standard equipment shall prevail.

(2). Defined by the IES TM-30-18 method, this data is for trial.

(3). Defined by the EBU, TLCI is the abbreviation of Television Lighting Consistency Index, this data is for trial.

Characteristics

Absolute maximum ratings ($T_A = 25^\circ\text{C}$)

PARAMETER	SYMBOL	RED	GREEN	BLUE	White	UNIT
Power Consumption (Simultaneous)	P_D	44	96	96	96	mW
DC Forward Current (Individual)	I_F	20	30	30	30	mA
Reverse Voltage	V_R			5		V
Operating Temperature	T_{opr}			-40 ~ +85		$^\circ\text{C}$
Storage Temperature	T_{stg}			-40 ~ +85		$^\circ\text{C}$
Junction Temperature	T_j			100		$^\circ\text{C}$

Chromaticity group and diagram

Chromaticity bins & coordinates

CCT	BIN	CIE 1931 COORDINATES							
		X0	Y0	X1	Y1	X2	Y2	X3	Y3
3200K	32N	0.4181	0.3888	0.4119	0.3959	0.4262	0.4090	0.4326	0.4021
5600K	56T	0.3242	0.3299	0.3234	0.3447	0.3376	0.3573	0.3370	0.3412

CIE 1931 diagram

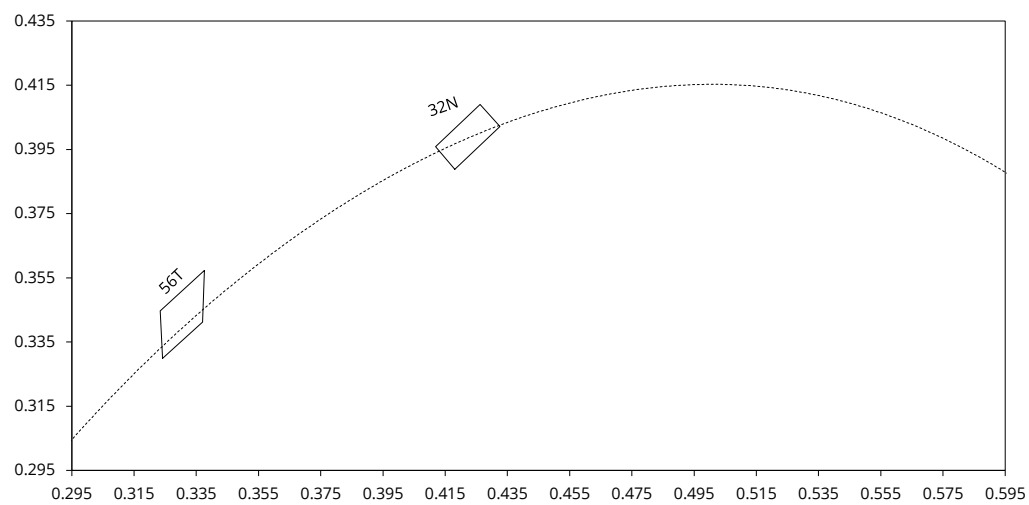

Package material and dimension

Package layout

All dimensions in mm, tolerance unless mentioned is ± 0.15 mm.

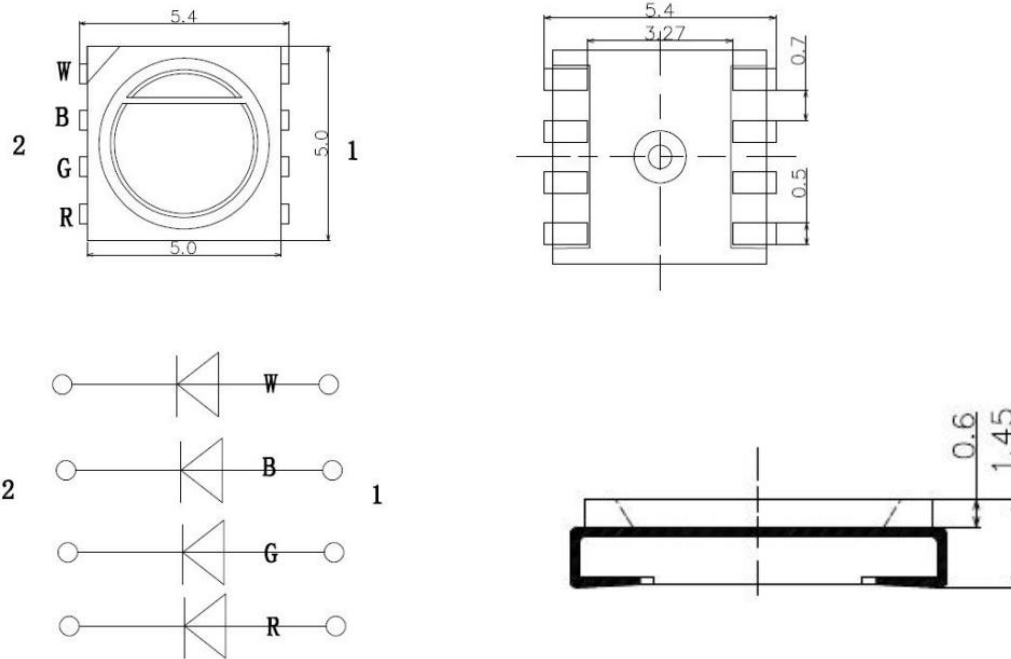

Characteristic graph

Typical spectral power distribution (normalized)

All characteristic curves are for reference only and not guaranteed.

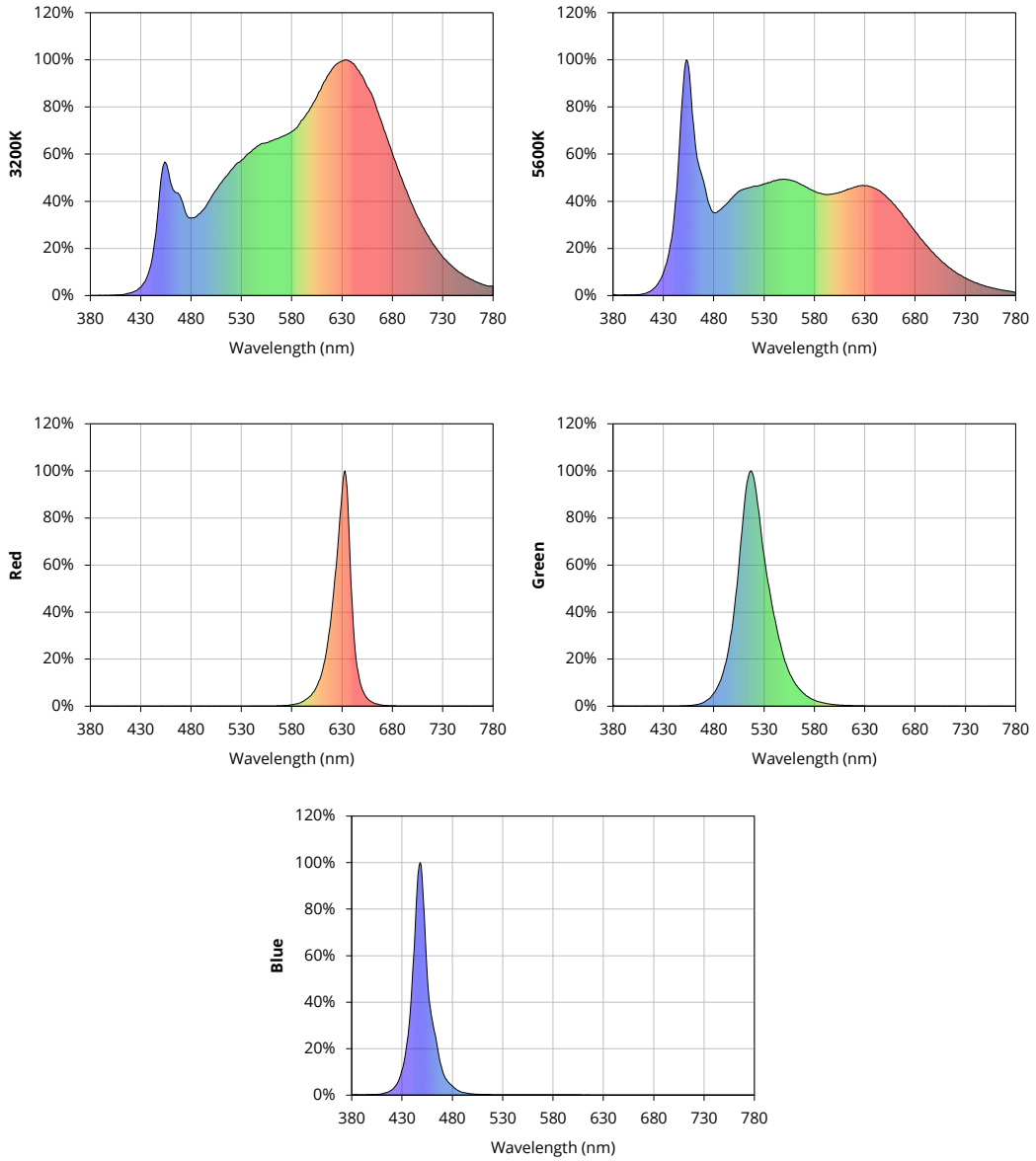

Characteristic graph

Spatial distribution ($T_A = 25^\circ\text{C}$, $I_F = 20\text{mA}$)

All characteristic curves are for reference only and not guaranteed.

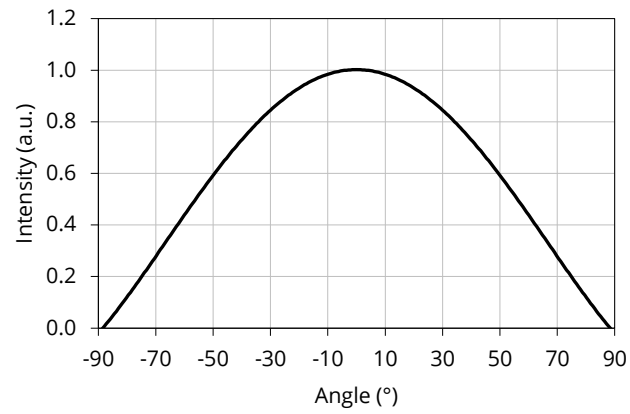

Reflow profile

Soldering ramp-up time (Pb-FREE).

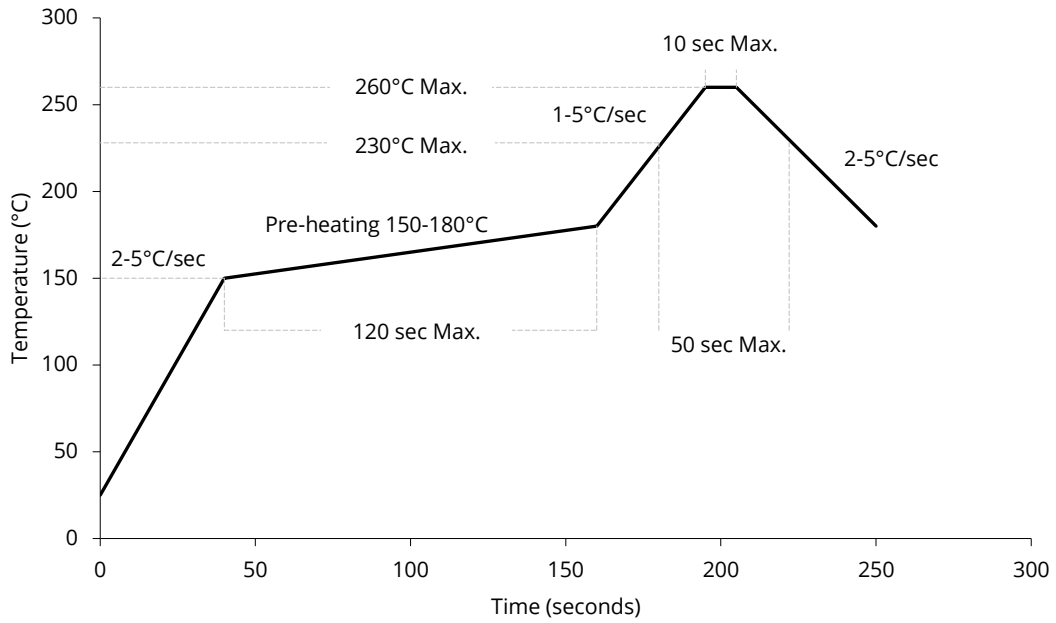

Note: Soldering paste with the melting point at 230°C is recommended.

SMT instruction

Problems caused by improper selection of collet

Choosing the right collet is important in ensuring product quality after SMT. LEDs are different from other electronic components, as they are not only concerned with electrical output but also optical output. This characteristic makes LEDs more fragile in the process of SMT. If the collet's lowering height is not well set, it will bring damage to the gold wire at the time of collet's pick-and-place process which can cause the LED to not illuminate, flicker or contribute to other quality problems, some of which may not be immediately detectable.

Collet selection

During SMT, please choose the appropriate collet in order to avoid damage the gold wire inside the LED or insufficient suction. Setting the height of the collet is crucial in order to avoid damage to the top view SMD. If the collet setting is set to too low of an altitude, the collet will press down on the SMD, causing damage or breakage to the encapsulant and cause distortion or breakage of the gold wire.

Other notes of caution

- No pressure should be exerted to the epoxy shell of the SMD under high temperature.
- Do not scratch or wipe the lens since the lens and gold wire inside are rather fragile and cross out easy to break.
- LED should be used as soon as possible when being taken out of the original package, and should be stored in anti-moisture and anti-ESD package.
- This usage and handling instructions are for reference only.

About Yujileds



Our story - Start from the superior stable red LED phosphor.

We started to make LED phosphor materials in 2006. White LEDs were still in very early stage, the industry focused on improving device brightness and efficiency via yellow phosphor very much. No one cared about the light quality. Based on this situation, we took a different approach and focused on red phosphor technology, which is the most important phosphor recipe for high CRI and/or low CCT LEDs, and it made Yuji become a JV partner with Mitsubishi Chemical from 2012.

Today, we are well known for our comprehensive research and full line-up production of LED phosphor from ultra-violet to near-infrared, and we are proud to commit to providing superior stable and efficient phosphors to the worldwide markets.

Our technology - Focus on LED spectrum innovation.

The industrial structure of both phosphor and LED gives us a unique view to develop our spectrum recipes. Compared to the general LED manufacturers, we have comprehensive information in evaluating the feasibility for both technical and commercial aspects. LED spectrum technology is not only about the quality of white LEDs, but also for different applications which have specialized requirements in lighting.

Yuji is one of the few companies that provide the service of designing or customizing a specific spectrum for clients, our confidence comes from the years of accumulation in focusing on the spectrum technologies and the control of LED phosphor and LED die supply-chain with thousands of successful cases in the past years. Innovating LED technologies and giving them commercial values are our eternal driving forces.

Our product - Yujileds®, stands for high-performance LED.

The trademark of Yujileds® is the identification of the LED products developed and manufactured by Yuji. We put our understanding of the LED technologies and the standard of our quality control into every LED we make. Regardless of any product series, we pay attention to expressing the high-performance feature and achieving the product value for clients and never compromise in pursuing the true performance.

Furthermore, we also care about every detail of any documentation we prepare for the product because we

understand the importance to transmit accurate information to clients. It is even more critical for clients to obtain the truth to decide the solution, rather than just a nominal high-performance.

Our client - Outstanding game players in different fields.

Clients are our proudest achievements, now over 200 of our clients are the best game players in their fields in more than 33 countries. We regard the clients' successes as our biggest accomplishments and appreciate their contribution in different fields, clients use our LEDs not just for simple lighting, but to design the lighting for plants, cameras, sensors, health, circadian rhythm, animals, and other industries that we have never imagined that our technologies can be utilized, that makes our work so meaningful.

Our service - Professional supporting team.

There is a group of people in Yuji passionate about creating maximum value for our clients. We have accumulated experience in different projects. Currently, the company gathers more than 30 experts from various fields of semiconductor, chemistry, optics, photoelectricity, circuitry, materials and color science.

Our sales team is well trained in deep LED technologies and has skilled global communication experience. Not just for sales, our team is more like a specialized consultancy to help every client succeed in different projects, and we do not only provide professional business service, but also support in the supply chain, logistics, marketing and technical discussions.

Contact us - We look forward to providing our efficient service for you.

LED website: www.yujiintl.com

Find Yujileds® high-performance LEDs, read our insights into a variety of advanced technologies and applications.

Contact: info@yujigroup.com

LED lighting website: www.yujilighting.com

Find our state-of-art LED lamps and luminaires designed for improving the lighting experience with the vision of illuminating the future.

Contact: lighting@yujigroup.com

Online shop: store.yujiintl.com

Shop your favorite Yuji Lighting product with rapid and professional service.

Contact: webstore@yujigroup.com