



YJ-WB-3030N(D)-G01

Surface Mount Device

Applications

- Circadian rhythm stimulus lighting
- High-end architectural lighting
- Human-centric lighting
- Biological research



Features

- Optimized M/P ratio and MDER
- Excellent biological comfortable
- Blue-light-hazard excluded
- Consistent and uniform chromaticity
- 1.5 W high power LED

[About Yujileds[®]](#)

Rev Version: 2.1

P3220026.00 & P3220027.00

Table of Contents

General description	3
Ordering information	6
Characteristics	7
Electrical-optical characteristics ($T_A = 25^\circ\text{C}$, 250mA)	7
Absolute maximum ratings ($T_A = 25^\circ\text{C}$)	8
Chromaticity group.....	9
Chromaticity bins & coordinates.....	9
Package material and dimension.....	10
Package layout.....	10
Characteristic graph	11
Typical spectral power distribution (normalized)	11
Forward current (2200K)	12
Vs. forward voltage	12
Vs. relative luminous flux.....	12
Vs. relative chromaticity shift	13
Vs. absolute chromaticity shift.....	13
Derating based on solder point	13
Forward current (4000K)	14
Vs. forward voltage	14
Vs. relative luminous flux.....	14
Vs. relative chromaticity shift	15
Vs. absolute chromaticity shift.....	15
Derating based on solder point	15
Characteristic graph	16
Spatial distribution ($T_A = 25^\circ\text{C}$, $I_F = 65\text{mA}$).....	16
Solder and reflow profile	17
Recommended solder pad layout.....	17
Reflow profile.....	17
SMT instruction	18
About Yujileds	19

General description

The Yujileds® Wlbeing series LED aims to provide the effective circadian rhythm stimulus lighting for both focusing and relaxing by the well-designed spectral engineering technologies. Unlike the visual sensitivity of 555nm, the intrinsically photosensitive retinal ganglion cells (ipRGCs) perceive the light wavelength at 480nm (typical) which affects the secretion of melanopsin, and melanopsin determines the circadian rhythm directly. A high-level radiance at 480nm will restrain the melanopsin secretion hence making us alert and focused, and a low-level radiance at 480nm is helpful for relaxation or pre-sleep.

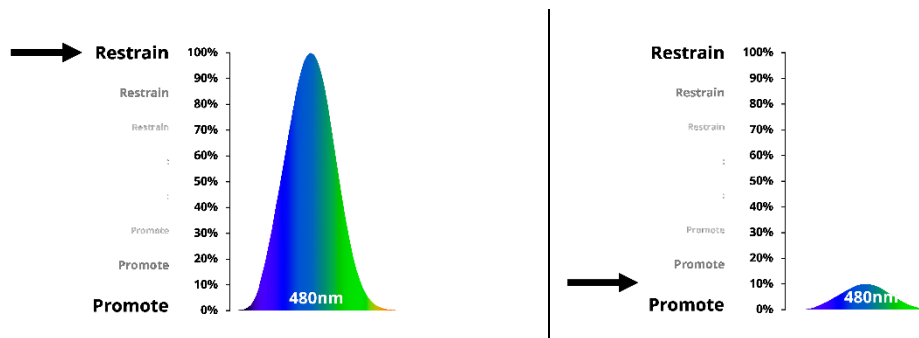

Therefore, the right proportion and weight of centered 480nm (typical) radiance in the spectrum design are the key factors for circadian rhythm regulation.

Wlbeing series LED spectrum science

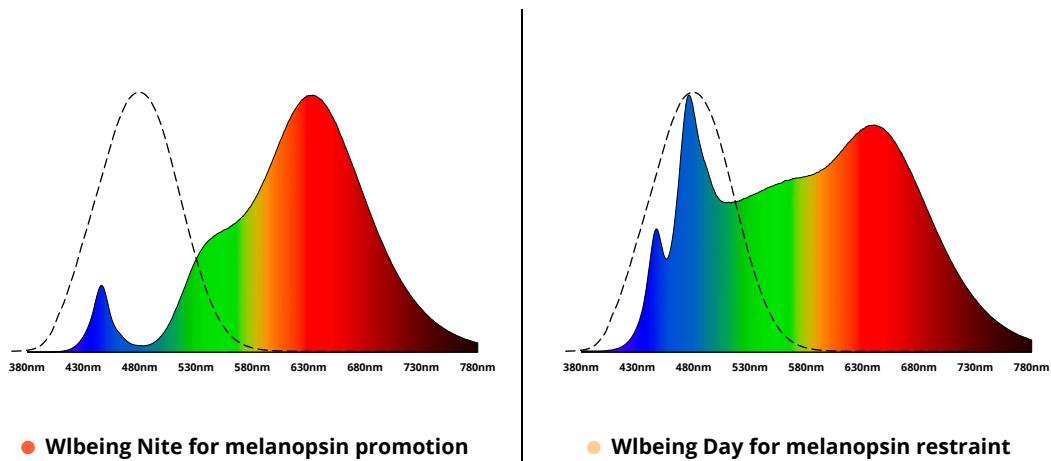

We develop and provide two essential spectrum theories of Nite for melanopsin promotion and Day for melanopsin restraint. For example, the Wlbeing 2200K is designed as warm white for relaxing lighting environment. To promote the melanopsin secretion, the spectrum is designed to isolate the ipRGCs sensitivity limited to 26% proportion; On the other hand, the Wlbeing 4000K is designed as neutral white for focusing lighting

environment. To restrain the melanopsin secretion, the spectrum is designed to fill the ipRGCs sensitivity sufficiently with up to 80% proportion.

Standard white colors with different circadian effect

The chromaticities of Yujileds® Wlbeing are compliant with the standard white LED lighting (ANSI C78.377-2017), hence they provide the same visual effect as a general LED, but are significantly different when measuring with Melanopic / Photopic ratio (M/P ratio) and Melanopic DER (MDER).

	Standard 2200K	Yujileds® Wlbeing Nite 2200K	Standard 2700K	Yujileds® Wlbeing Nite 2700K
M/P ratio	0.40	0.294 (↘28%)	0.53	0.375 (↘30%)
MDER	0.36	0.268 (↘25%)	0.48	0.342 (↘30%)
	Standard 4000K	Yujileds® Wlbeing Day 4000K	Standard 5000K	Yujileds® Wlbeing Day 5000K
M/P ratio	0.76	0.906 (↗20%)	0.93	1.015 (↗9%)
MDER	0.69	0.825 (↗20%)	0.85	0.925 (↗9%)

High CRI for high-quality lighting

With our spectral engineering abilities and Yuji phosphor technology, Yujileds® Wlbeing Nite and Day are designed to 85-95 CRI, that is to say, the Wlbeing LEDs satisfy both visual (color reproduction) and invisible (circadian stimulus) effects and can be widely used in high-end commercial lighting.

The Wlbeing series 3030 LED also supports the unique service/certification by Yujileds® as described below.

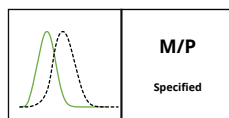

M/P
Specified

M/P ratio specification

For comparing the circadian effect between the ipRGC sensitivity and photopic vision.

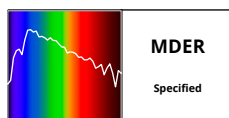

MDER
Specified

MDER specification

For evaluating the circadian effect of the melanopsin secretion based on the CIE S 026/E:2018.



RoHS 2011/65/EU compliance

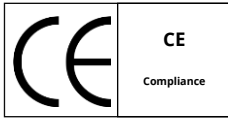

CE compliance



REACH compliance (Phosphor)

Ordering information

PART NUMBER	PRODUCT CODE	CCT	CHROMATICITY BINS	VOLTAGE RANGE
YJ-WB-3030N-G01-22	P3220026.22	2200K	W22L, W22R	-
YJ-WB-3030N-G01-27	P3220026.27	2700K	W27L, W27R	-
YJ-WB-3030D-G01-40	P3220027.40	4000K	W40L, W40R	-
YJ-WB-3030D-G01-50	P3220027.50	5000K	W50L, W50R	-
YJ-WB-3030N-G01-XX	P3200026.XX	-	-	-
YJ-WB-3030D-G01-XX	P3200027.XX	-	-	-

Characteristics

Electrical-optical characteristics ($T_A = 25^\circ\text{C}$, 250mA)

PARAMETER	SYMBOL	VALUE			UNIT	TOLERANCE
		MIN.	TYP.	MAX.		
Forward voltage	V_F	6.2	-	6.6	V	± 0.05
Luminous flux	Φ_{2200K}	125	-	140	lm	-
	Φ_{2700K}	125	-	140		
	Φ_{4000K}	125	-	140		
	Φ_{5000K}	140	-	160		
Correlated color temperature⁽¹⁾	CCT_{2200K}	-	2200	-	K	-
	CCT_{2700K}	-	2700	-		
	CCT_{4000K}	-	4000	-		
	CCT_{5000K}	-	5000	-		
Color rendering index	Nite	85	-	-	-	± 1
	Day	90	-	-	-	± 1
Melanopic Photopic Ratio⁽²⁾	M/P_{2200K}	-	0.294	-	-	-
	M/P_{2700K}	-	0.375	-	-	-
	M/P_{4000K}	-	0.906	-	-	-
	M/P_{5000K}	-	1.015	-	-	-
Melanopic Daylight Efficacy Ratio⁽³⁾	$MDER_{2200K}$	-	0.268	-	-	-
	$MDER_{2700K}$	-	0.342	-	-	-
	$MDER_{4000K}$	-	0.825	-	-	-
	$MDER_{5000K}$	-	0.925	-	-	-
Reverse current	I_r	-	-	5	μA	$\pm 0.1 (V_r = 5V)$
View angle	$2\theta_{1/2}$	-	120	-	Deg	± 5

(1). Yujileds® promises the chromaticity coordinate tolerance of ± 0.01 (CIE 1931 x,y) based on Yuji standard equipment shall prevail.

(2). M/P Ratio stands for Melanopic Photopic Ratio, also Known as MEER, Melanopic Equal-Energy Efficacy Ratio.

(3). MDER stands for Melanopic Daylight Efficacy Ratio following the definition in CIE S 0.25:2018.

Characteristics

Absolute maximum ratings ($T_A = 25^\circ\text{C}$)

PARAMETER	SYMBOL	LIMIT	UNIT
Power Consumption	P_D	2000	mW
DC Forward Current (pulsed)⁽¹⁾	I_{FP}	320 ⁽²⁾	mA
DC Forward Current	I_F	320	mA
Reverse Voltage	V_R	5	V
Operating Temperature	T_{opr}	-40 ~ +85	°C
Storage Temperature	T_{stg}	-30 ~ +100	°C
Soldering Temperature	T_{sol}	260 ± 5 (<10s)	°C
ESD	-	8	kV
Reflow Cycles Allowed	-	2	-

(1). Pulse width $\leq 0.1\text{ms}$, duty $\leq 1/10$.

(2). Theoretical data.

Chromaticity group

Chromaticity bins & coordinates

CCT	BIN	CIE 1931 COORDINATES							
		X0	Y0	X1	Y1	X2	Y2	X3	Y3
2200K	W22L	0.4860	0.3930	0.4860	0.4130	0.5000	0.4190	0.5000	0.3990
	W22R	0.5000	0.3990	0.5000	0.4190	0.5140	0.4250	0.5140	0.4050
2700K	W27L	0.4420	0.3950	0.4420	0.4150	0.4560	0.4200	0.4560	0.4000
	W27R	0.4560	0.4000	0.4560	0.4200	0.4700	0.4250	0.4700	0.4040
4000K	W40L	0.3700	0.3590	0.3700	0.3800	0.3820	0.3910	0.3820	0.3700
	W40R	0.3820	0.3700	0.3820	0.3910	0.3940	0.4010	0.3940	0.3800
5000K	W50L	0.3400	0.3330	0.3400	0.3550	0.3520	0.3710	0.3520	0.3490
	W50R	0.3520	0.3490	0.3520	0.3710	0.3640	0.3870	0.3640	0.3650

CIE 1931 diagram

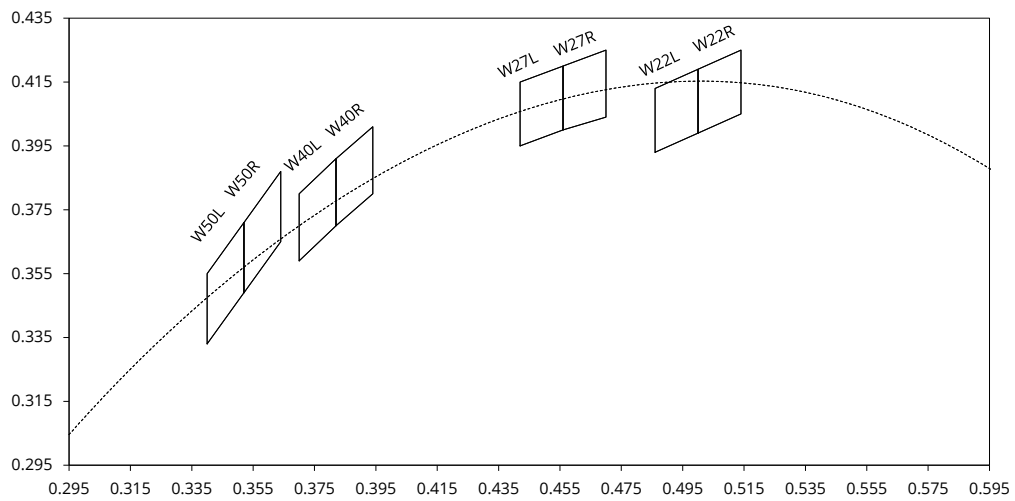

Package material and dimension

Package layout

All dimensions in mm, tolerance unless mentioned is ± 0.1 mm.

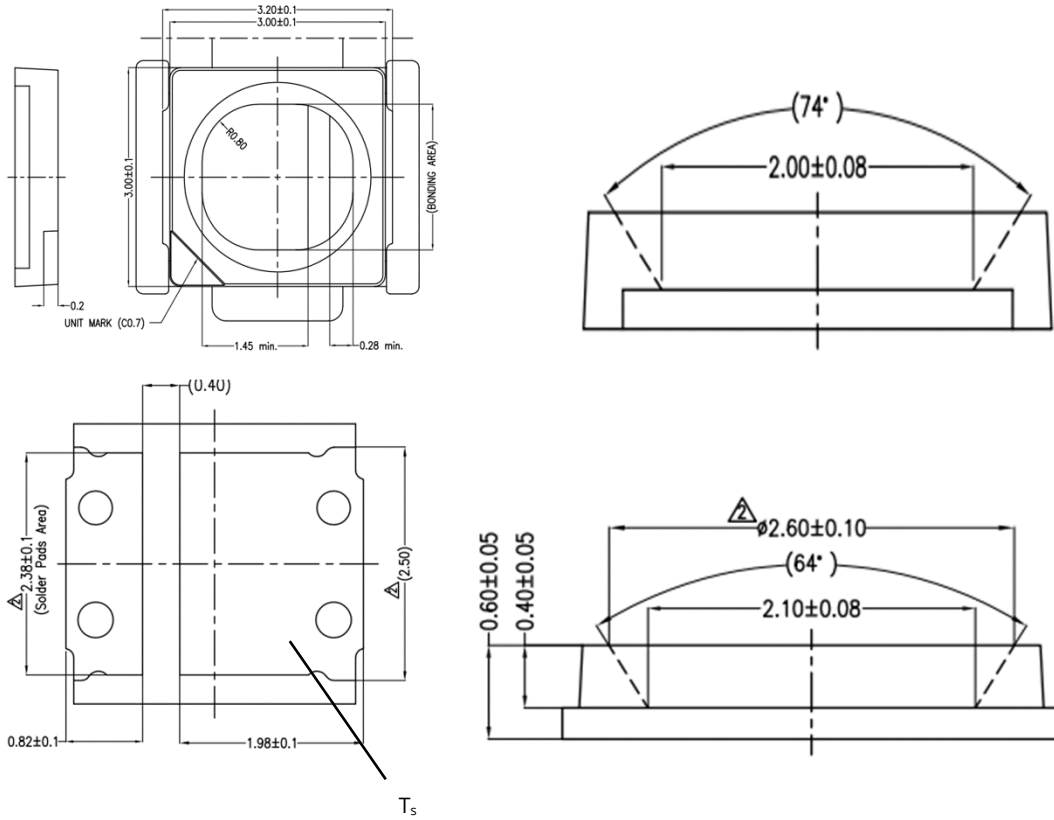

Characteristic graph

Typical spectral power distribution (normalized)

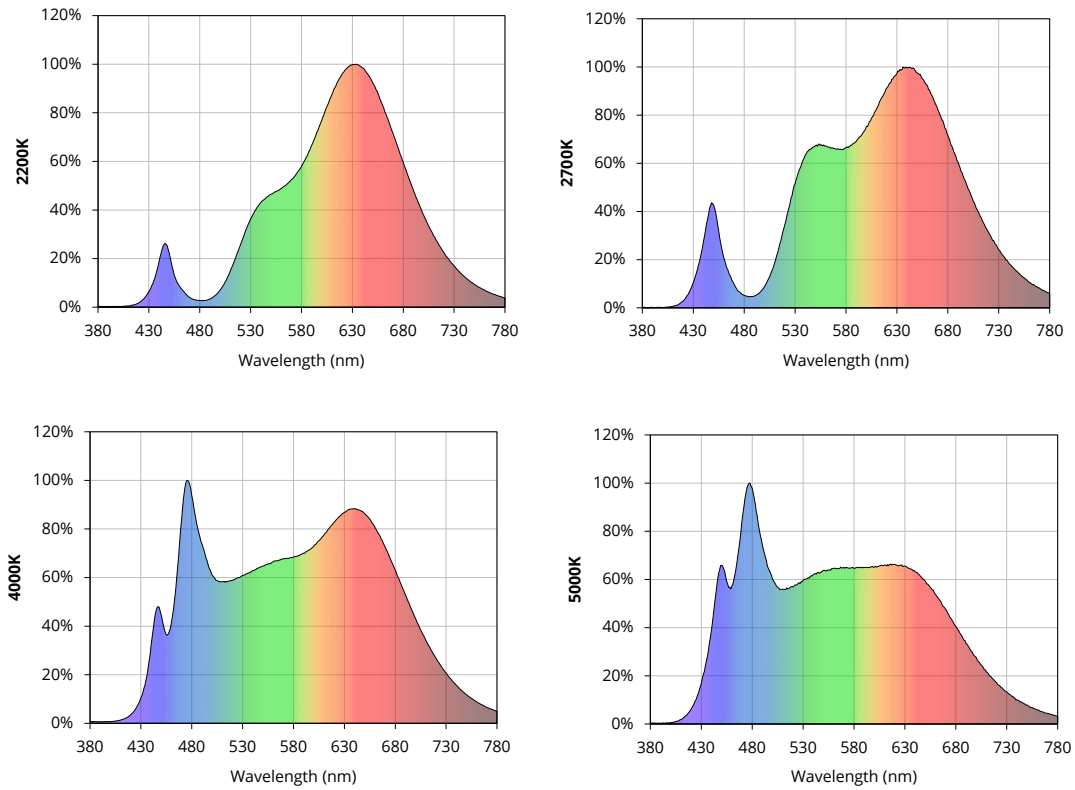

Characteristic graph

Forward current (2200K)

All characteristic curves are for reference only and not guaranteed.

Vs. forward voltage

($T_A = 25^\circ\text{C}$)

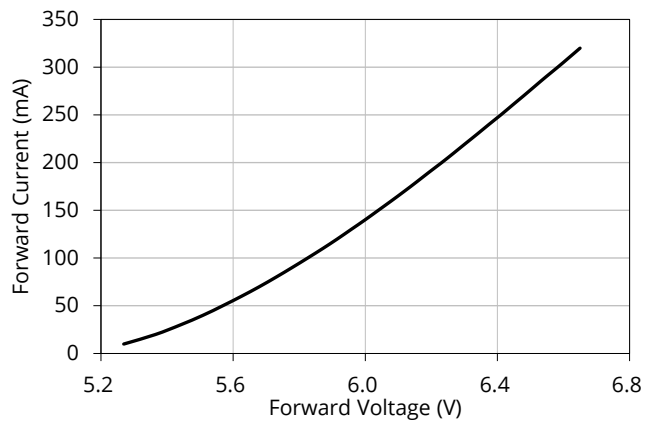

Vs. relative luminous flux

($T_A = 25^\circ\text{C}$)

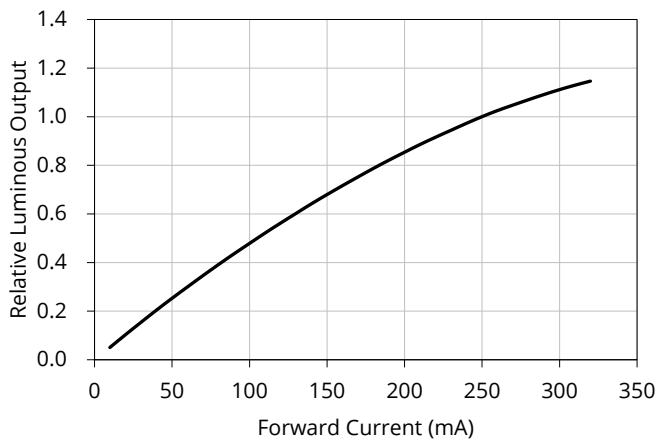

Characteristic graph

Forward current (2200K, continued)

All characteristic curves are for reference only and not guaranteed.

Vs. relative chromaticity shift

($T_A = 25^\circ\text{C}$)

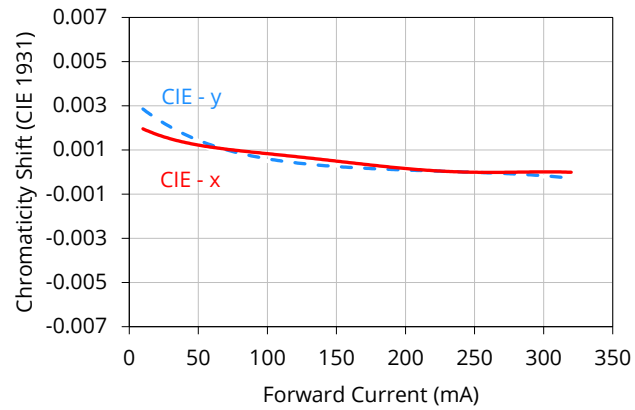

Vs. absolute chromaticity shift

($T_A = 25^\circ\text{C}$)

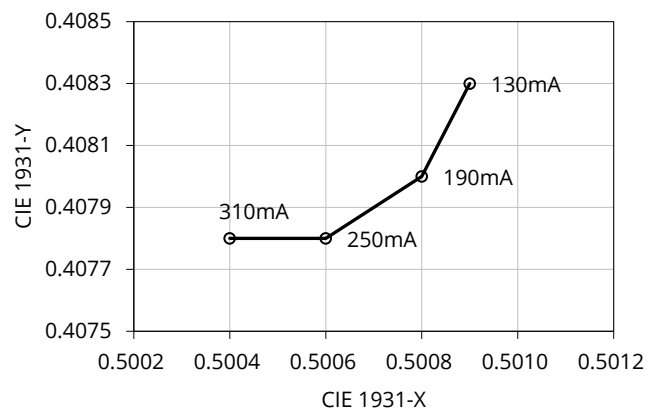

Derating based on solder point

Note: De-rating curves are meant for recommendation only and are not meant to provide guarantees of product stability and longevity.

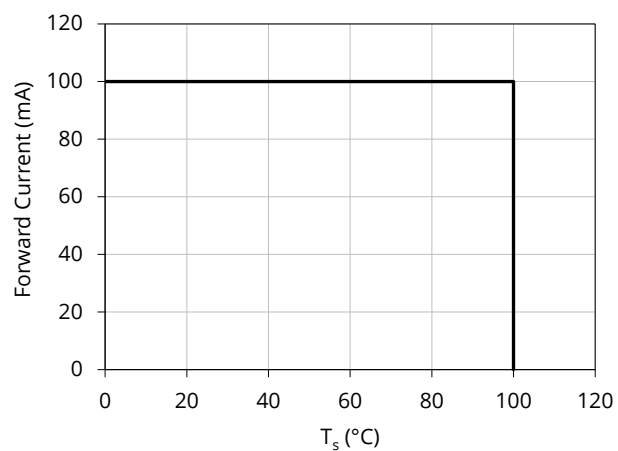

Characteristic graph

Forward current (4000K)

All characteristic curves are for reference only and not guaranteed.

Vs. forward voltage

($T_A = 25^\circ\text{C}$)

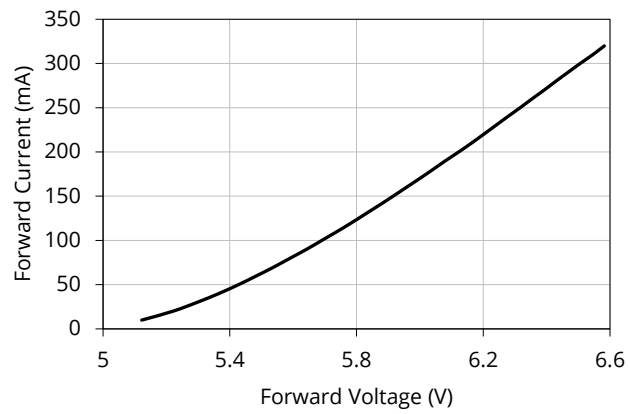

Vs. relative luminous flux

($T_A = 25^\circ\text{C}$)

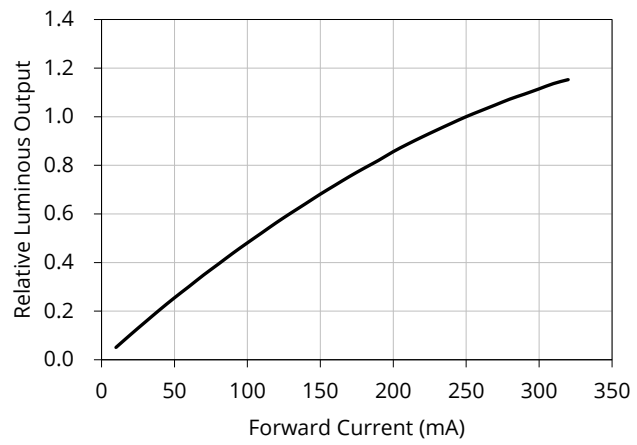

Characteristic graph

Forward current (4000K, continued)

All characteristic curves are for reference only and not guaranteed.

Vs. relative chromaticity shift

($T_A = 25^\circ\text{C}$)

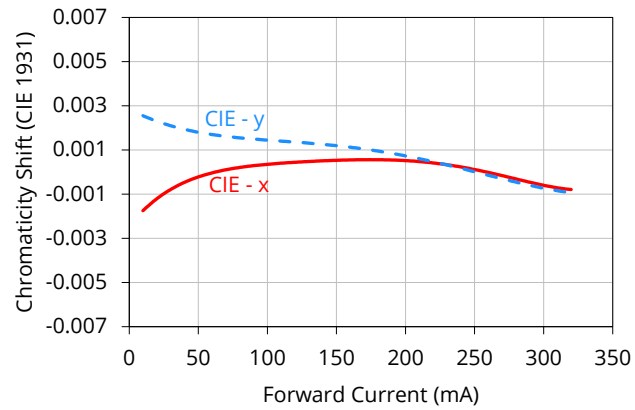

Vs. absolute chromaticity shift

($T_A = 25^\circ\text{C}$)

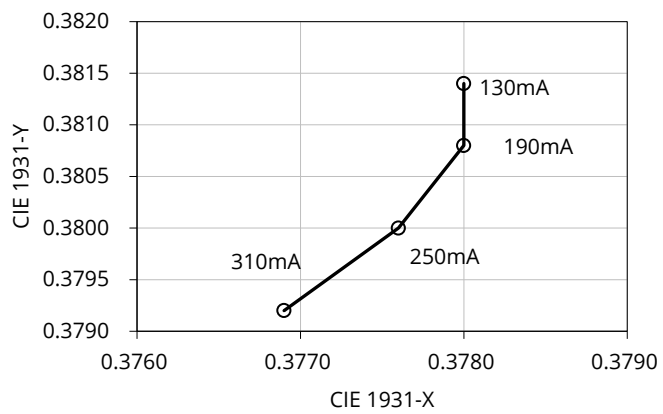

Derating based on solder point

Note: De-rating curves are meant for recommendation only and are not meant to provide guarantees of product stability and longevity.

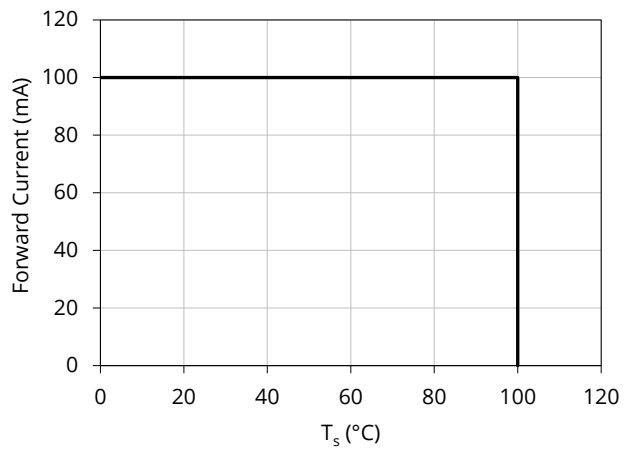

Characteristic graph

Spatial distribution ($T_A = 25^\circ\text{C}$, $I_F = 250\text{mA}$)

All characteristic curves are for reference only and not guaranteed.

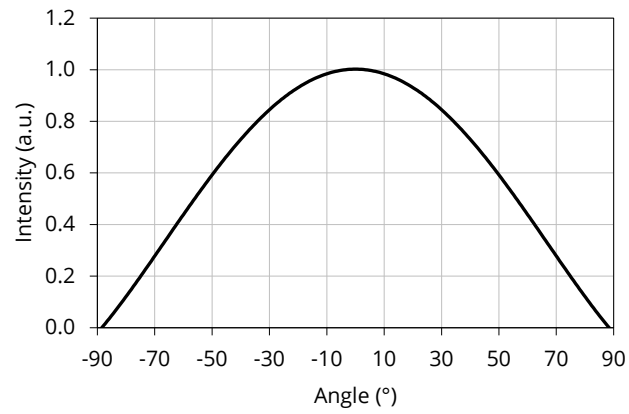

Solder and reflow profile

Recommended solder pad layout

All dimensions in mm, tolerance unless mentioned is ± 0.1 mm.

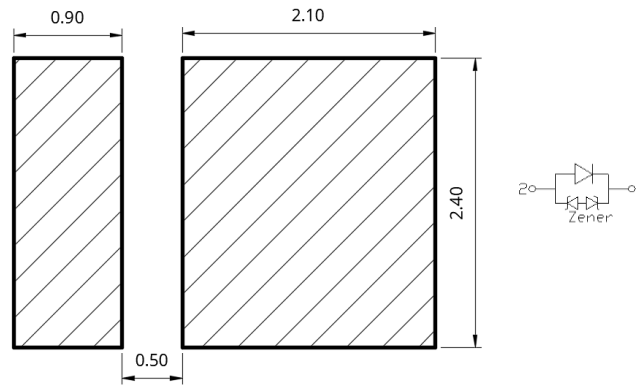

Reflow profile

Soldering ramp-up time (Pb-FREE).

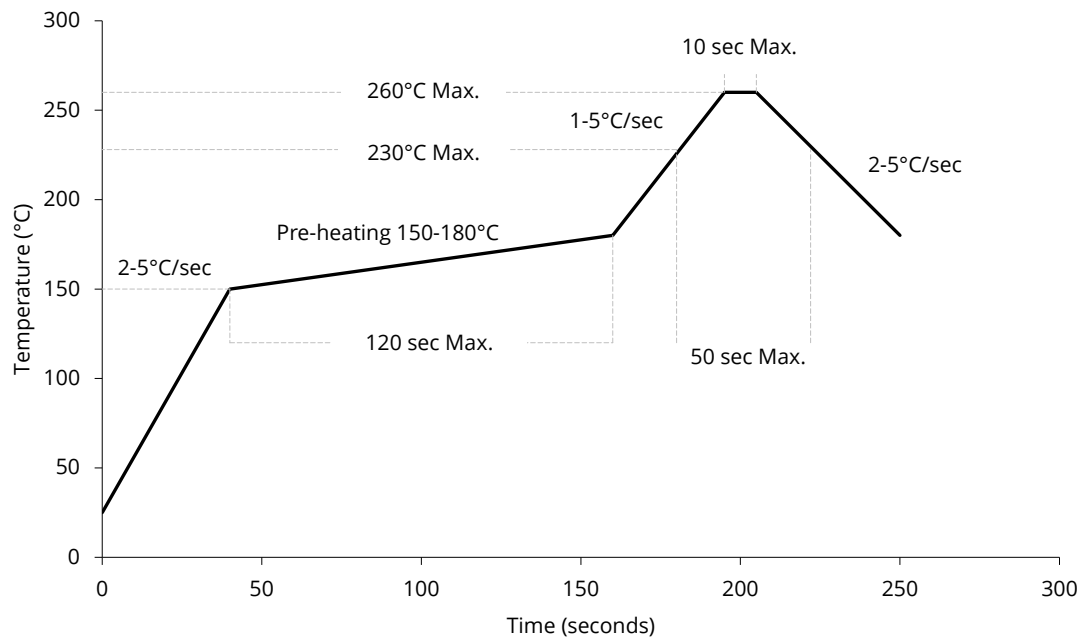

Note: Soldering paste with the melting point at 230°C is recommended.

SMT instruction

Problems caused by improper selection of collet

Choosing the right collet is important in ensuring product quality after SMT. LEDs are different from other electronic components, as they are not only concerned with electrical output but also optical output. This characteristic makes LEDs more fragile in the process of SMT. If the collet's lowering height is not well set, it will bring damage to the gold wire at the time of collet's pick-and-place process which can cause the LED to not illuminate, flicker or contribute to other quality problems, some of which may not be immediately detectable.

Collet selection

During SMT, please choose the appropriate collet in order to avoid damage the gold wire inside the LED or insufficient suction. Setting the height of the collet is crucial in order to avoid damage to the top view SMD. If the collet setting is set to too low of an altitude, the collet will press down on the SMD, causing damage or breakage to the encapsulant and cause distortion or breakage of the gold wire.

Other notes of caution

- No pressure should be exerted to the epoxy shell of the SMD under high temperature.
- Do not scratch or wipe the lens since the lens and gold wire inside are rather fragile and cross out easy to break.
- LED should be used as soon as possible when being taken out of the original package, and should be stored in anti-moisture and anti-ESD package.
- This usage and handling instructions are for reference only.

About Yujileds



Our story - Start from the superior stable red LED phosphor.

We started to make LED phosphor materials in 2006. White LEDs were still in very early stage, the industry focused on improving device brightness and efficiency via yellow phosphor very much. No one cared about the light quality. Based on this situation, we took a different approach and focused on red phosphor technology, which is the most important phosphor recipe for high CRI and/or low CCT LEDs, and it made Yuji become a JV partner with Mitsubishi Chemical from 2012.

Today, we are well known for our comprehensive research and full line-up production of LED phosphor from ultra-violet to near-infrared, and we are proud to commit to providing superior stable and efficient phosphors to the worldwide markets.

Our technology - Focus on LED spectrum innovation.

The industrial structure of both phosphor and LED gives us a unique view to develop our spectrum recipes. Compared to the general LED manufacturers, we have comprehensive information in evaluating the feasibility for both technical and commercial aspects. LED spectrum technology is not only about the quality of white LEDs, but also for different applications which have specialized requirements in lighting.

Yuji is one of the few companies that provide the service of designing or customizing a specific spectrum for clients, our confidence comes from the years of accumulation in focusing on the spectrum technologies and the control of LED phosphor and LED die supply-chain with thousands of successful cases in the past years. Innovating LED technologies and giving them commercial values are our eternal driving forces.

Our product - Yujileds®, stands for high-performance LED.

The trademark of Yujileds® is the identification of the LED products developed and manufactured by Yuji. We put our understanding of the LED technologies and the standard of our quality control into every LED we make. Regardless of any product series, we pay attention to expressing the high-performance feature and achieving the product value for clients and never compromise in pursuing the true performance.

Furthermore, we also care about every detail of any documentation we prepare for the product because we

understand the importance to transmit accurate information to clients. It is even more critical for clients to obtain the truth to decide the solution, rather than just a nominal high-performance.

Our client - Outstanding game players in different fields.

Clients are our proudest achievements, now over 200 of our clients are the best game players in their fields in more than 33 countries. We regard the clients' successes as our biggest accomplishments and appreciate their contribution in different fields, clients use our LEDs not just for simple lighting, but to design the lighting for plants, cameras, sensors, health, circadian rhythm, animals, and other industries that we have never imagined that our technologies can be utilized, that makes our work so meaningful.

Our service - Professional supporting team.

There is a group of people in Yuji passionate about creating maximum value for our clients. We have accumulated experience in different projects. Currently, the company gathers more than 30 experts from various fields of semiconductor, chemistry, optics, photoelectricity, circuitry, materials and color science.

Our sales team is well trained in deep LED technologies and has skilled global communication experience. Not just for sales, our team is more like a specialized consultancy to help every client succeed in different projects, and we do not only provide professional business service, but also support in the supply chain, logistics, marketing and technical discussions.

Contact us - We look forward to providing our efficient service for you.

LED website: www.yujiintl.com

Find Yujileds® high-performance LEDs, read our insights into a variety of advanced technologies and applications.

Contact: info@yujigroup.com

LED lighting website: www.yujilighting.com

Find our state-of-art LED lamps and luminaires designed for improving the lighting experience with the vision of illuminating the future.

Contact: lighting@yujigroup.com

Online shop: store.yujiintl.com

Shop your favorite Yuji Lighting product with rapid and professional service.

Contact: webstore@yujigroup.com