

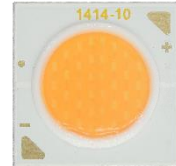

YJ-APS-1313L-G01

Chip-on-board LED

StandardWhite



Applications

- High-end architectural lighting
- Healthy lighting
- Photoelectric device and relevant research

Features

- 99% similarity to the sunlight spectrum
- Industrial high CRI performance
- 10W power consumption
- 13.5 mm × 13.5 mm chip-on-board LED
- Φ 8.4mm LES (Light-Emitting Surface)
- TLCI & TM-30 specified
- SimpleBinning solution

[About Yujileads[®]](#)

Rev Version: 2.0

P3220037.00

Table of Contents

General description	3
Ordering information	8
Characteristics	9
Electrical-optical characteristics ($T_A = 25^\circ\text{C}$, 300mA)	9
Absolute maximum ratings ($T_A = 25^\circ\text{C}$)	10
Chromaticity group and diagram	11
Chromaticity bins & coordinates	11
CIE 1931 diagram.....	11
Package material and dimension.....	12
Package layout.....	12
Package materials.....	12
Characteristic graph	13
Typical spectral power distribution (normalized).....	13
Forward current.....	14
Vs. forward voltage.....	14
Vs. relative luminous flux.....	14
Vs. relative chromaticity shift	15
Vs. absolute chromaticity shift	15
Derating based on solder point	16
Solder point temperature (T_s).....	17
Vs. forward voltage.....	17
Vs. relative luminous flux.....	17
Vs. relative chromaticity shift	18
Spatial distribution ($T_A = 25^\circ\text{C}$, $I_F = 100\text{ mA}$)	18
About Yujileds	19

General description

The APS series LED is designed for creating a new era of natural lighting spectrum LED with superb color rendering performance. Improving the artificial lighting as close to the sunlight is the eternal pursuit for the top LED manufacturers. However, the artificial lighting gets far away from the naturalness after the incandescent and halogen because the illumination principles of the later artificial lights are far away from the blackbody radiation, including LED.

The sun essentially provides complete and homogenous spectral radiation in the visual wavelengths, while an LED is always combined by the blue or purple semiconductor die with blue/green/amber/red phosphors, in consequence, it is visualized to observe that from an LED spectrum, peaks and gaps always exist because of the respective characteristics of the die and phosphors, which can not be avoided generally.

99% similarity to the sunlight spectrum

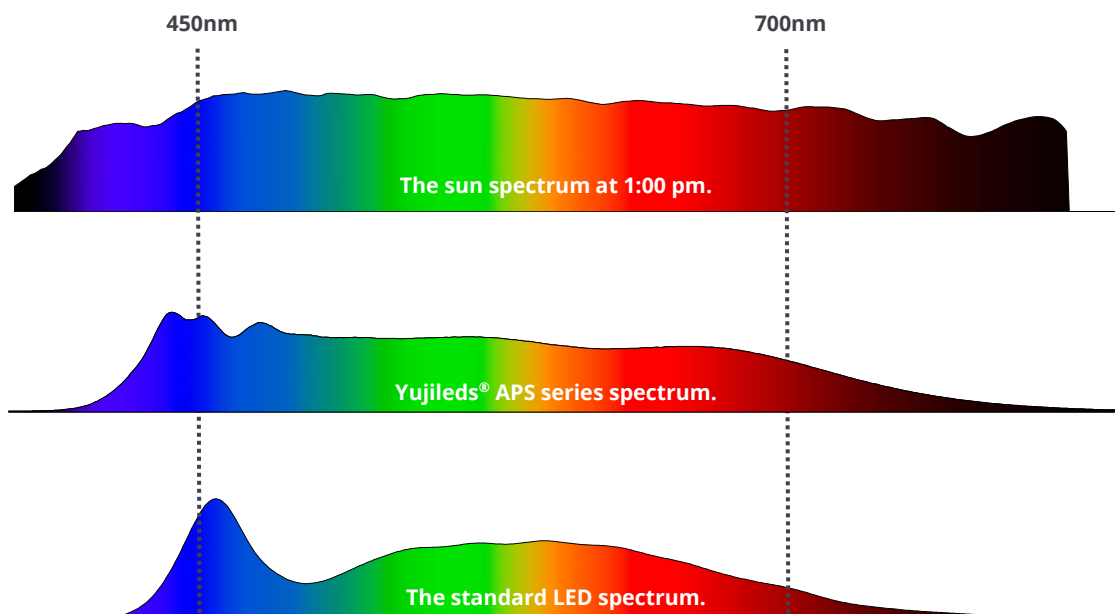

Yujileds® APS series LED is based on innovative and revolutionary technologies. It provides an unprecedented spectrum with ultra-homogeneous features within one compact package, where the color rendition performs superbly and stably. Compared to these standards, the APS spectra achieve 99% similarity within one compact package, unprecedented for all of the Yujileds® high CRI LEDs ever.

Compared to other sun spectrum LED solutions, the APS series LED utilizes the die and

phosphor technologies effectively that achieves full-spectrum coverage in visual wavelengths, which improves the luminous efficacy (lm/W) and maintenance to a great extent.

Refuse any peaks or gaps

Ideal illuminants always present completely uniform spectral power distributions, such as sunlight where a recent artificial light source can never simulate to a promising degree, especially for LED considering its particular illuminating principle. With the latest technology of Yujileds® phosphor and package, it is finally available to achieve homogeneous spectra and there is no longer a strong peak or obvious gap like a standard LED.

Ri up to 100, steadily

Yujileds® APS series LED is equally top level under CRI metric system. Achieving up to 99, R1-R15 all above 90 or even 100, the APS series LED performs steadily in color rendition, which helps with reducing the concerns of the imperfection when rendering specific colors. Even for the always mentioned contradiction between R9 and R12 is well solved in the APS series LED.

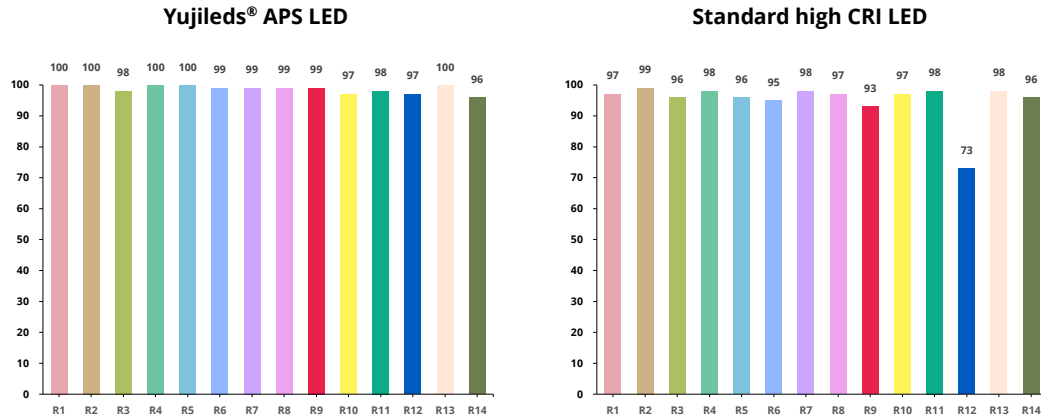

Superlative performance in TM-30 metric valuation

TM-30 is widely recognized as the new and more comprehensive metric to evaluate the color rendition of the LED light source, it provides more references including color fidelity and gamut from 99 evaluation samples, which means, compared to conventional metrics, the TM-30 will disclose more details to present the most authentic performance on color rendition.

The APS series TM-30 measurements are the most intuitive testifications. Given the Rf 98

Rg 100, and the average of all 99 color fidelities above 95, each color fidelity is more than 90. These values mean that Yujileds® APS series technology wins the highest level on the color rendition, not only for individual metrics but is stable quality.

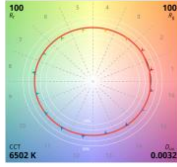
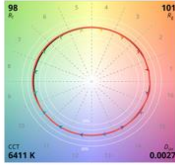
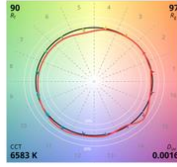
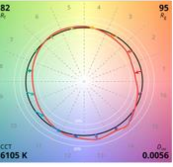
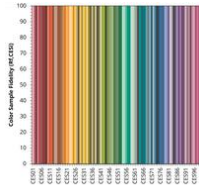
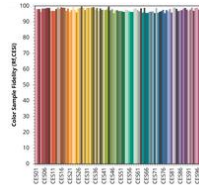
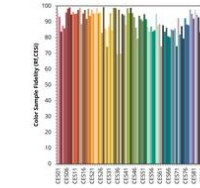
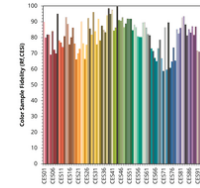
	Natural light	Yujileds® APS LED	Standard high CRI LED	Standard LED
Fidelity index (Rf)	100	98	90	82
Gamut index (Rg)	100	100	97	95
Fidelity of 99 CES	All = 100	All > 90	Average 90	Average 82
Color Vector Graphic (CVG)				
Color Sample Fidelity				

Specialized StandardWhite binning

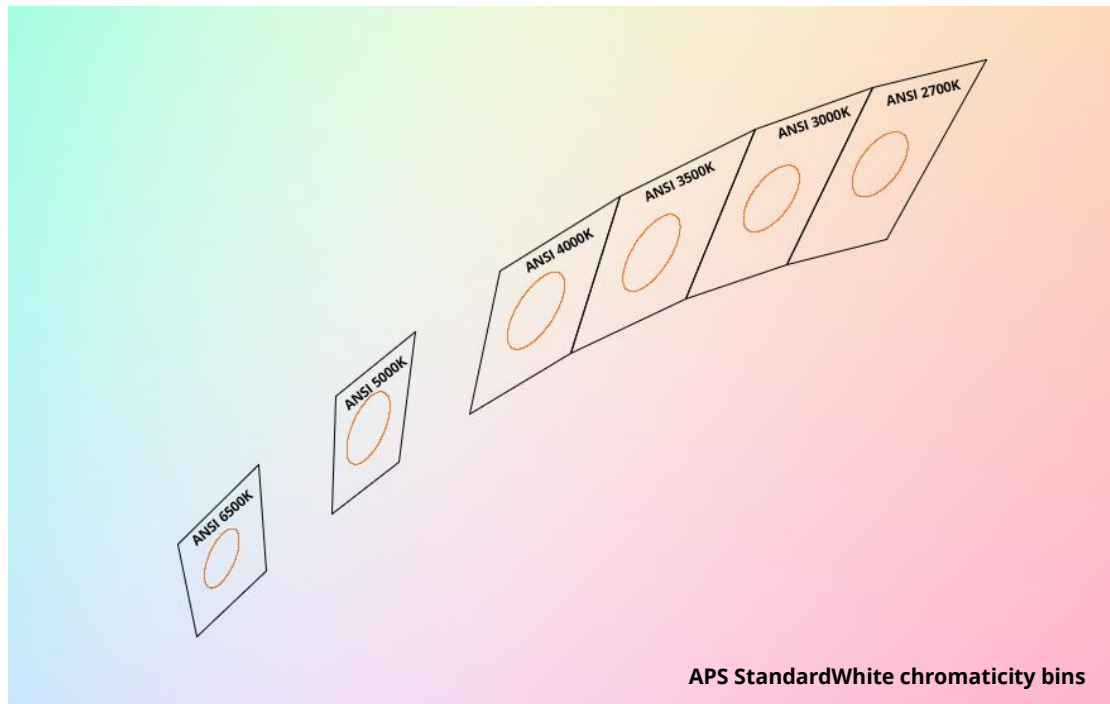

In order to provide highly consistent chromaticities, Yujileds® offers ANSI 3-step bin, and

with SimpleBinning technologies based on Yujileds® module, the lighting design is simplified greatly but no compromise on color quality, the equivalent consistency can be expected to 2-step SDCM.

The first choice for high-performance LED

The revolutionary meaning of Yujileds® APS series LED is not only about its remarkable spectrum quality, but is the balanced achievement of cost, efficacy, maintenance and color rendering. Compared to competitors’ LED, the APS series LED is more friendly for commercialization in different applications.

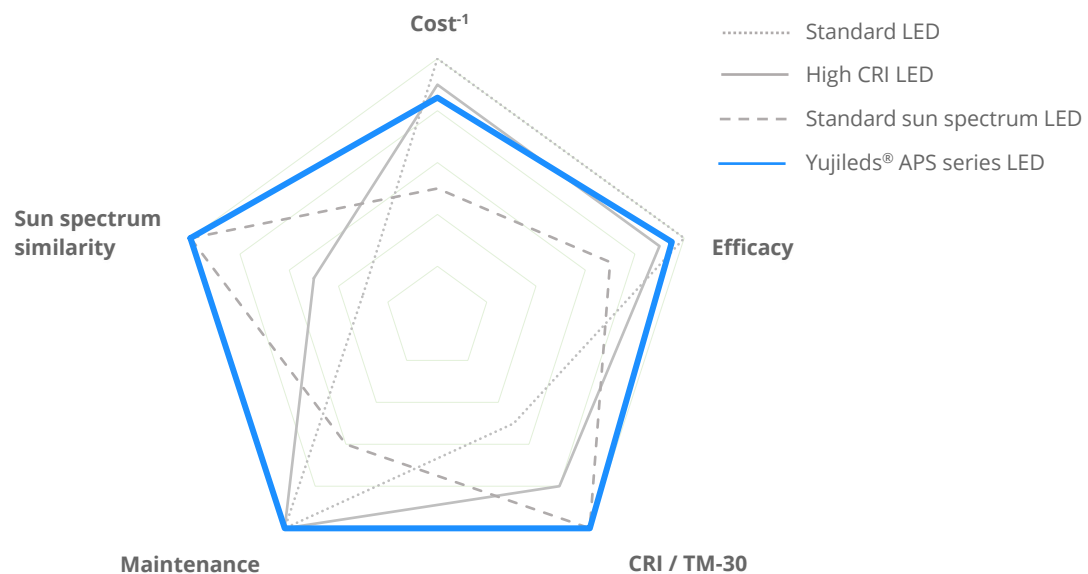

The APS series LED also supports the unique service/certification by Yujileds® as described below.



TM-30 specification

The most advanced colorimetric for color rendition, widely recognized as the successor of CRI.



TLCI specification

Based on the Macbeth ColorChecker, for evaluating the colorimetric quality of the broadcast lighting.

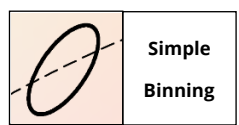

SimpleBinning specification

Simplify the chromaticity binning with TrueChroma data support to provide the most economical, simple, and practical solution to customers.

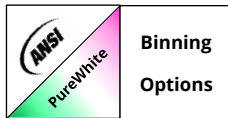

**Binning
Options**

Binning options for Standard or PureWhite

Besides the industrial standard binning (ANSI 3-step), the optional PureWhite binning can provide balanced and precise white colors.



**RoHS
Compliance**

RoHS 2011/65/EU compliance

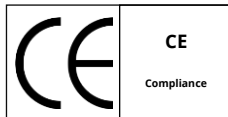

**CE
Compliance**

CE compliance



**REACH
Compliance**

REACH compliance (Phosphor)

Ordering information

PART NUMBER	PRODUCT CODE	CCT	CHROMATICITY BINS	VOLTAGE BIN
YJ-APS-1313L-G01-27	P3220037.27	2700K	27A	V32
YJ-APS-1313L-G01-30	P3220037.30	3000K	30A	V32
YJ-APS-1313L-G01-40	P3220037.40	4000K	40A	V32
YJ-APS-1313L-G01-XX	P3220037.XX	Custom CCT	-	V32

Characteristics

Electrical-optical characteristics ($T_A = 25^\circ\text{C}$, 300mA)

PARAMETER	SYMBOL	VALUE			UNIT	TOLERANCE
		MIN.	TYP.	MAX.		
Forward voltage	V_F	32	-	39	V	± 0.05
Luminous flux	Φ_{2700K}	800	-	900	lm	-
	Φ_{3000K}	850	-	950		
	Φ_{4000K}	950	-	1050		
Correlated color temperature⁽¹⁾	CCT_{2700K}	-	2700	-	K	-
	CCT_{3000K}	-	3000	-		
	CCT_{4000K}	-	4000	-		
Color rendering index	Ra	97	-	-	-	± 1
	Ri (i = 1-15)	90	-	-	-	-
Fidelity index⁽²⁾	Rf	-	98	-	-	-
Gamut index⁽²⁾	Rg	-	100	-	-	-
TLCI 2012⁽³⁾	-	-	99	-	-	-
Reverse current	I_r	-	-	10	μA	± 0.1 ($V_r = 15\text{V}$)
View angle	$2\theta_{1/2}$	-	120	-	Deg	± 5

(1). Yujileds® promises the chromaticity coordinate tolerance of ± 0.0015 (CIE 1931 x,y) based on Yuji standard equipment shall prevail.

(2). Defined by the IES TM-30 method, this data is for trial.

(3). Defined by the EBU, TLCI is the abbreviation of Television Lighting Consistency Index, this data is for trial.

Characteristics

Absolute maximum ratings ($T_A = 25^\circ\text{C}$)

PARAMETER	SYMBOL	LIMIT	UNIT
Power Consumption	P_D	13500	mW
DC Forward Current (pulsed)⁽¹⁾	I_{FP}	900 ⁽²⁾	mA
DC Forward Current	I_F	450	mA
Reverse Voltage	V_R	60	V
Junction Temperature	T_j	125	$^\circ\text{C}$
Case Temperature⁽³⁾	T_c	85	$^\circ\text{C}$
Operating Temperature	T_{opr}	-40 ~ +85	$^\circ\text{C}$
Storage Temperature	T_{stg}	-40 ~ +85	$^\circ\text{C}$

(1). Pulse width $\leq 0.1\text{ms}$, duty $\leq 1/10$.

(2). Theoretical data.

(3). See page [Package material and dimension](#).

Chromaticity group and diagram

Chromaticity bins & coordinates

CCT	BIN	CIE 1931 COORDINATES					SDCM	Refer to CCT
		X	Y	a	b	θ		
2700K	27A	0.4578	0.4101	0.00810	0.00420	49.70	3	2650 - 2800 K
3000K	30A	0.4338	0.4030	0.00834	0.00408	50.22	3	2950 - 3150 K
4000K	40A	0.3818	0.3797	0.00939	0.00402	54.80	3	3850 - 4150 K

CIE 1931 diagram

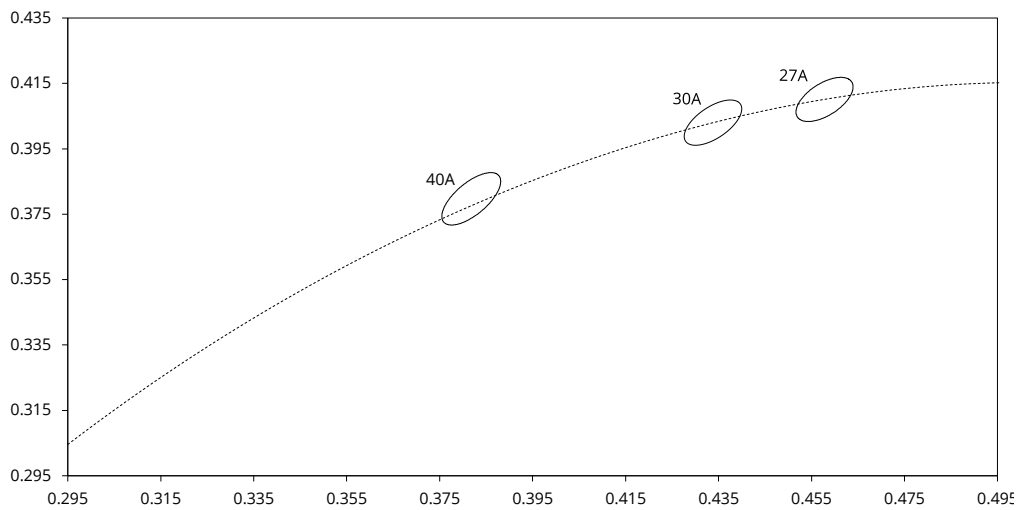

Package material and dimension

Package layout

All dimensions in mm, tolerance unless mentioned is ± 0.1 mm.

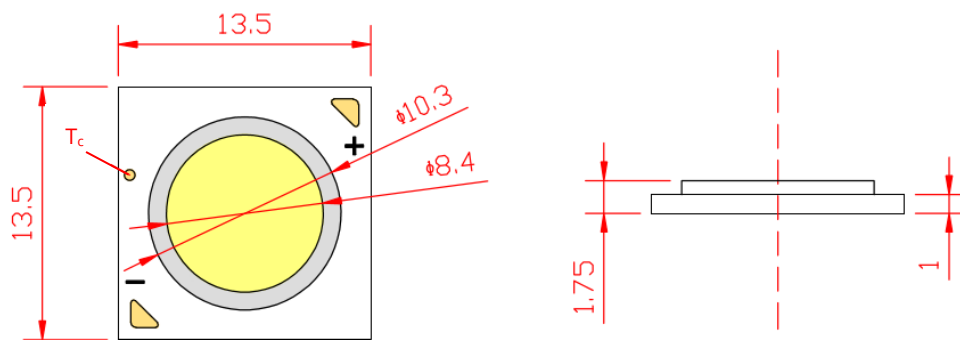

Package materials

ITEM	DESCRIPTION
Die material	InGaN
Lead frame material	MPCB
Encapsulant resin material	Silicone + Phosphor

Characteristic graph

Typical spectral power distribution (normalized)

All characteristic curves are for reference only and not guaranteed.

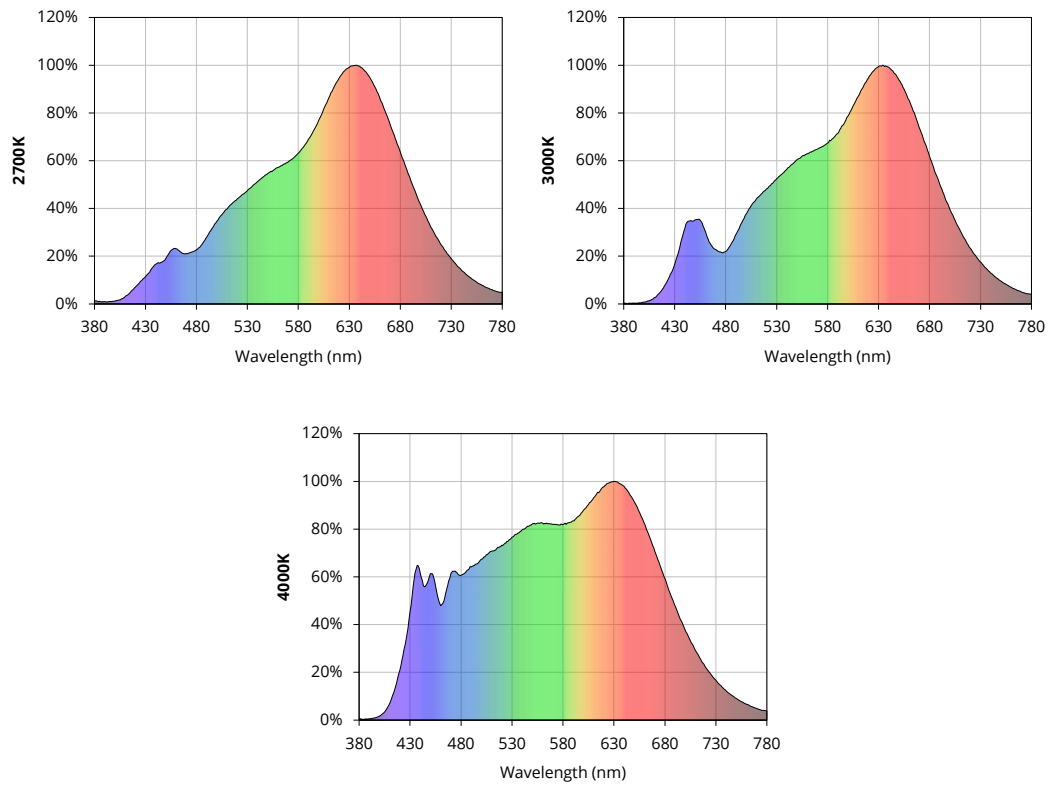

Characteristic graph

Forward current

All characteristic curves are for reference only and not guaranteed.

Vs. forward voltage

($T_A = 25^\circ\text{C}$)

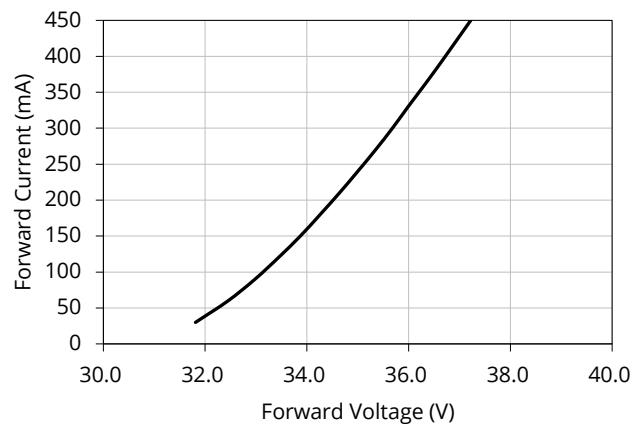

Vs. relative luminous flux

($T_A = 25^\circ\text{C}$)

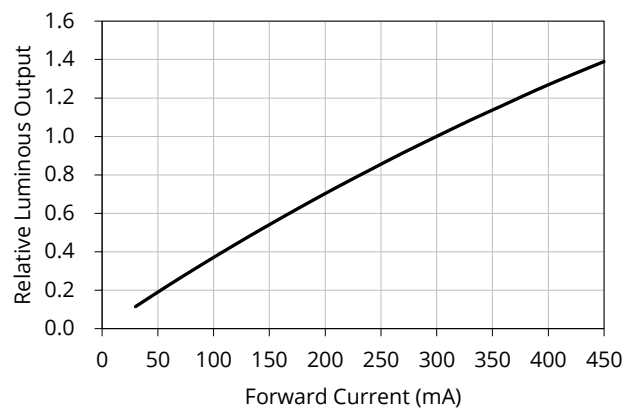

Characteristic graph

Forward current (continued)

All characteristic curves are for reference only and not guaranteed.

Vs. relative chromaticity shift

(3000K, $T_A = 25^\circ\text{C}$)

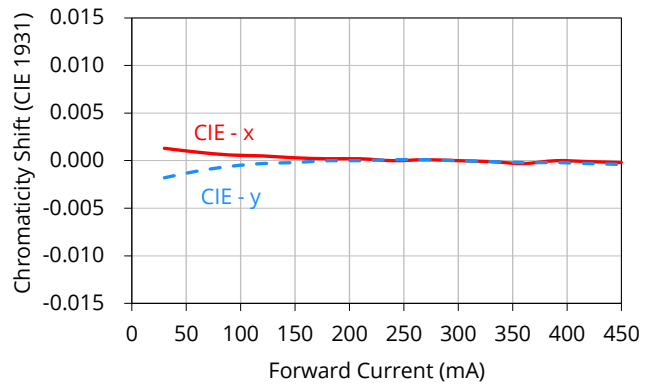

Vs. absolute chromaticity shift

(3000K, $T_A = 25^\circ\text{C}$)

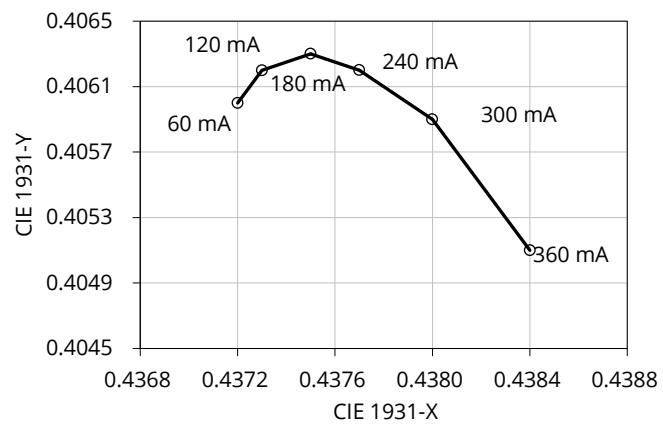

Characteristic graph

Forward current (continued)

All characteristic curves are for reference only and not guaranteed.

Derating based on case
temperature

Note: De-rating curves are meant for
recommendation only and are not meant
to provide guarantees of product stability
and longevity.

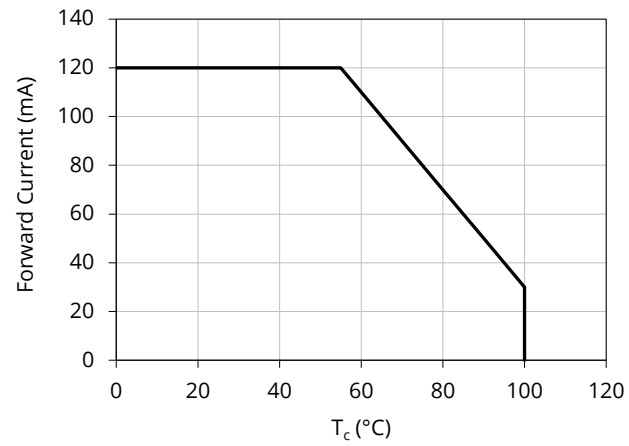

Characteristic graph

Case temperature (T_c)

All characteristic curves are for reference only and not guaranteed.

Vs. forward voltage

($I_F = 300\text{mA}$)

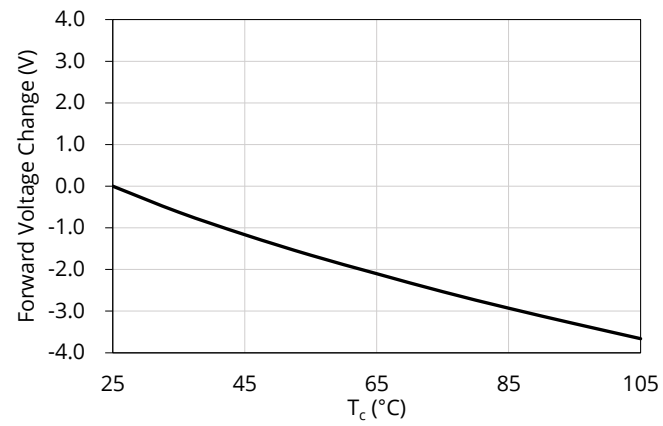

Vs. relative luminous flux

($I_F = 300\text{mA}$)

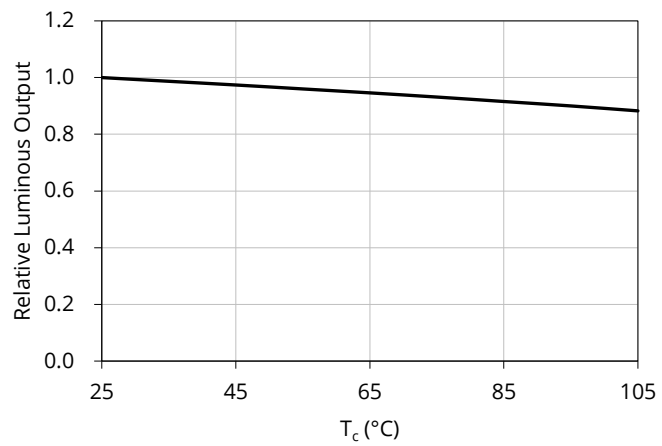

Characteristic graph

Case temperature (T_c) (continued)

All characteristic curves are for reference only and not guaranteed

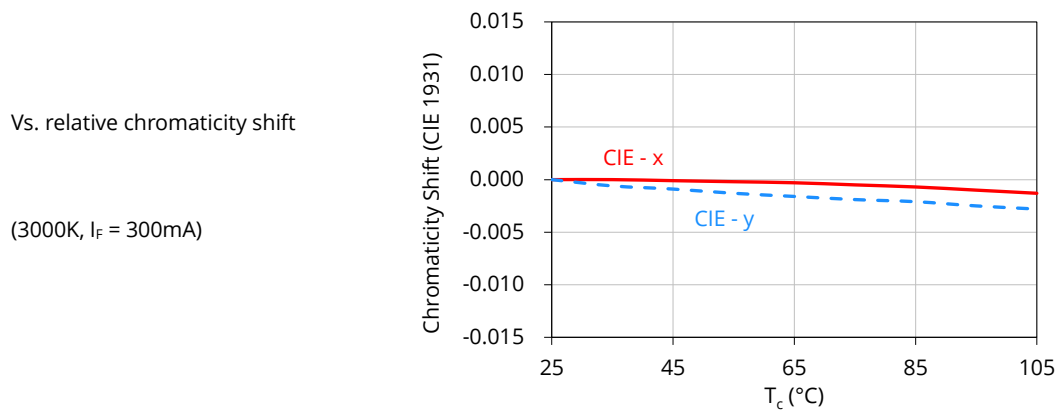

Spatial distribution ($T_A = 25^\circ\text{C}$, $I_F = 300\text{ mA}$)

All characteristic curves are for reference only and not guaranteed.

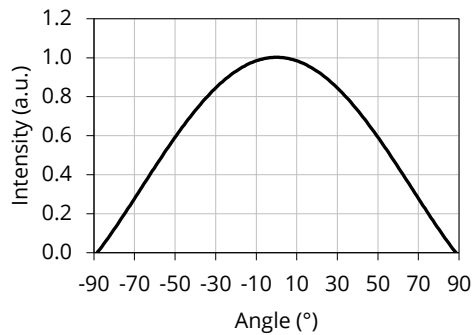

About Yujileds



Our story - Start from the superior stable red LED phosphor.

We started to make LED phosphor materials in 2006. White LEDs were still in very early stage, the industry focused on improving device brightness and efficiency via yellow phosphor very much. No one cared about the light quality. Based on this situation, we took a different approach and focused on red phosphor technology, which is the most important phosphor recipe for high CRI and/or low CCT LEDs, and it made Yuji become a JV partner with Mitsubishi Chemical from 2012.

Today, we are well known for our comprehensive research and full line-up production of LED phosphor from ultra-violet to near-infrared, and we are proud to commit to providing superior stable and efficient phosphors to the worldwide markets.

Our technology - Focus on LED spectrum innovation.

The industrial structure of both phosphor and LED gives us a unique view to develop our spectrum recipes. Compared to the general LED manufacturers, we have comprehensive information in evaluating the feasibility for both technical and commercial aspects. LED spectrum technology is not only about the quality of white LEDs, but also for different applications which have specialized requirements in lighting.

Yuji is one of the few companies that provide the service of designing or customizing a specific spectrum for clients, our confidence comes from the years of accumulation in focusing on the spectrum technologies and the control of LED phosphor and LED die supply-chain with thousands of successful cases in the past years. Innovating LED technologies and giving them commercial values are our eternal driving forces.

Our product - Yujileds®, stands for high-performance LED.

The trademark of Yujileds® is the identification of the LED products developed and manufactured by Yuji. We put our understanding of the LED technologies and the standard of our quality control into every LED we make. Regardless of any product series, we pay attention to expressing the high-performance feature and achieving the product value for clients and never compromise in pursuing the true performance.

Furthermore, we also care about every detail of any documentation we prepare for the product because we understand the importance to transmit accurate information to clients. It is even more critical for clients to obtain the truth to decide the solution, rather than just a nominal high-performance.

Our client - Outstanding game players in different fields.

Clients are our proudest achievements, now over 200 of our clients are the best game players in their fields in more than 33 countries. We regard the clients' successes as our biggest accomplishments and appreciate their contribution in different fields, clients use our LEDs not just for simple lighting, but to design the lighting for plants, cameras, sensors, health, circadian rhythm, animals, and other industries that we have never imagined that our technologies can be utilized, that makes our work so meaningful.

Our service - Professional supporting team.

There is a group of people in Yuji passionate about creating maximum value for our clients. We have accumulated experience in different projects. Currently, the company gathers more than 30 experts from various fields of semiconductor, chemistry, optics, photoelectricity, circuitry, materials and color science.

Our sales team is well trained in deep LED technologies and has skilled global communication experience. Not just for sales, our team is more like a specialized consultancy to help every client succeed in different projects, and we do not only provide professional business service, but also support in the supply chain, logistics, marketing and technical discussions.

Contact us - We look forward to providing our efficient service for you.

LED website: www.yujiintl.com

Find Yujileds® high-performance LEDs, read our insights into a variety of advanced technologies and applications.

Contact: info@yujigroup.com

LED lighting website: www.yujilighting.com

Find our state-of-art LED lamps and luminaires designed for improving the lighting experience with the vision of illuminating the future.

Contact: lighting@yujigroup.com

Online shop: store.yujiintl.com

Shop your favorite Yuji Lighting product with rapid and professional service.

Contact: webstore@yujigroup.com